

KT-EMRG-1400 /B

FLUORESCENT EMERGENCY BALLAST

ASSEMBLY AND INSTALLATION INSTRUCTIONS

WARNING: When using this lighting device, safety precautions should be followed at all times.

CAUTION: Verify that all replacement lamp types marked on the installed luminaire are also identified as suitable for use with this inverter/charger pack.

**READ THE INSTRUCTIONS BELOW CAREFULLY
AND FOLLOW THEM FOR YOUR OWN SAFETY.**

Note: The maximum mounting height for this model is 8ft

1. Prior to installation, battery connector must be open to prevent high voltage from being present on output leads (red and yellow). It must be connected only after installation is complete and AC power is supplied to the unit.
2. This unit can operate commonly used linear and compact fluorescent lamps.
Please refer to the lamps listed on the ballast label for specific lamp information.
3. Please ensure the electricity connections conform to the National Electrical Code and local regulations if applicable.
4. To avoid electric shock, please disconnect normal and emergency power supplies, and battery connector of the emergency ballast before servicing.
5. This device is designed for factory or field installation in either the ballast channel or on top of the fixture, except air handling heated air outlets, sealed and gasketed fixtures, wet or hazardous location fixtures. Do not install this device near gas or electric heaters.
6. AC power source of 120 VAC or 277 VAC is required.
7. The battery is sealed, no-maintenance, and is not replaceable in the field. Please contact manufacturer for information on service. Do not attempt to service the battery.
8. Do not use accessory equipment that is not recommended by manufacturer. Failure to do so may cause unsafe conditions. Servicing should only be performed by qualified service personnel.
9. Do not use the product for other than its intended purpose.

SAVE THESE INSTRUCTIONS



KT-EMRG-1400 /B

CAUTION: Before installing, make certain the AC power is off and the battery connector is disconnected.

1. MOUNTING THE EMERGENCY BALLAST (BATTERY PACK)

Remove the ballast channel cover. Mount the emergency ballast in the ballast channel at least 1/2" away from the AC ballast(s).

When battery packs are remote mounted, the remote distance can not exceed 1/2 of the distance from ballast to lamp specified by the AC ballast manufacturer. For example, if the AC ballast manufacturer recommends no more than 25' remote distance, then the battery pack's remote mounting distance should not exceed 12 1/2'. Under no circumstances should the battery pack exceed a distance of 50' from the lamp(s).

2. WIRING

Refer to the wiring diagrams on the back page for the appropriate wiring of lamp(s) and ballast. Install in accordance with the National Electrical Code and local regulations. For additional wiring diagrams consult customer service.

3. INSTALLING THE LED COMBO TEST SWITCH (LCTS)

Recessed Troffer Fixture: Select a convenient location with proper clearance in the ballast cover and drill or punch a 7/8" hole (1/2" knockout). Insert the 7/8" bushing into the hole. Push the plastic tube through the bushing. Route the leads of the LCTS through the plastic tube. Connect the wires from the unit to the LCTS (violet to violet, brown to brown). Push the entire assembly back into the tube until the lens collar rests against the plastic tube. The plastic tube should be adjusted so that the LCTS is within 1/4" of the fixture lens. The LCTS must be visible after installation. *Refer to Illustration 1.*

Strip Fixture: Select a convenient location on the fixture so the LCTS can be seen after installation. Allow for proper clearance inside the fixture and drill or punch a 1/2" hole. Remove the nut from the LCTS. Push the LCTS housing into the 1/2" hole and secure with the nut. Connect the wires from the LCTS (violet to violet, brown to brown). *Refer to Illustration 2.*

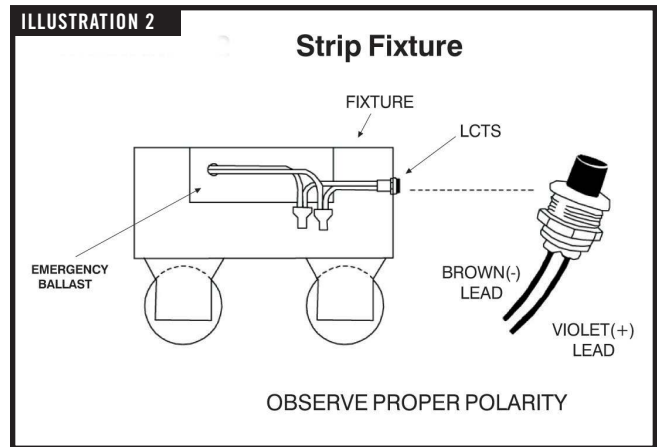
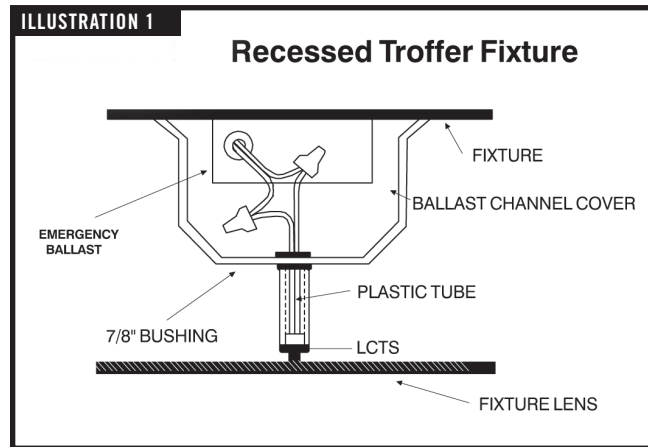

4. POWER SUPPLY

The emergency ballast and AC ballast must be on the same branch circuit. It requires an unswitched AC power source of either 120 or 277 volts. Select proper voltage lead and cap the unused lead. When the emergency ballast is used with a switched fixture, AC input to the emergency ballast must be connected ahead of the fixture switch. *Refer to Illustration 3 for switched and unswitched fixture wiring diagrams.*

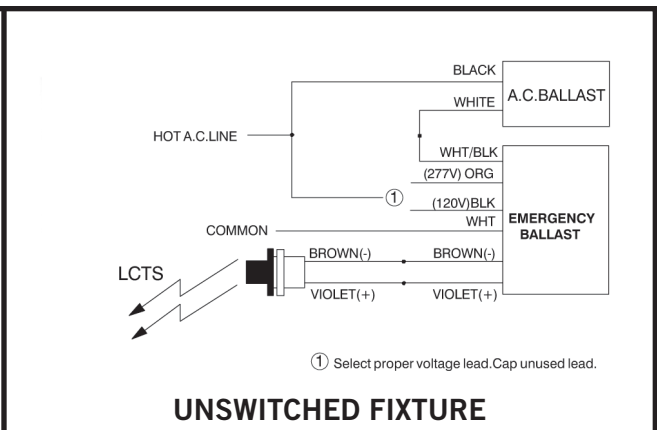
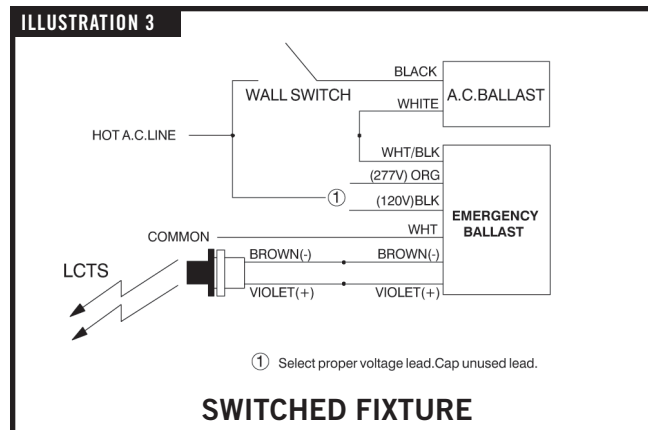

5. LABELS

Attach the appropriate labels adjacent to the LCTS. Annotate re-lamping label for lamp type and wattage. The caution and re-lamping labels must be on the fixture in a readily visible location to anyone attempting to service the fixture.

6. COMPLETING INSTALLATION

When the installation is complete, switch the AC power on and join the unit connector of the emergency ballast.

OPERATION

Normal Mode: AC power is present. The AC ballast operates the fluorescent lamp(s) as intended. The LCTS will be lit providing a visual indication that the emergency ballast is in the standby charging mode.

Emergency Mode: The AC power fails. The emergency ballast senses the AC power failure and automatically switches to the emergency mode. One or two lamps is illuminated at reduced output for a minimum of 90 minutes. When the AC power is restored, the emergency ballast switches the system back to the normal mode and resumes battery charging. (See page 1 of this manual.)

MAINTENANCE

Pressing the red lens on the LCTS turns off the light on the LCTS and forces the unit into emergency mode. This interrupts power to the emergency lamps only. The emergency lamp is now being lit by the emergency ballast unit and will be less bright than the other lamps in the system. To simulate a black out, use the circuit breaker to turn off AC power.

Initial Testing: Allow the unit to charge approximately 1 hour, then press the LCTS to conduct a short discharge test. Allow a 24 hour charge before conducting a 90 minute test.

The emergency ballast is a maintenance free unit, however, periodic inspection and testing is required. NFPA 101, Life Safety Code, outlines the following schedule:

Monthly: Insure that the LCTS is illuminated. Conduct a 30 second discharge test by depressing the LCTS. One or two lamps should operate at reduced output.

Annually: Insure that the LCTS is illuminated. Conduct a full 90 minute discharge test. The unit should operate as intended for the duration of the test.

Written records of testing shall be kept by the owner for inspection by the authority having jurisdiction.

SERVICING SHOULD BE PERFORMED ONLY BY QUALIFIED PERSONNEL.

KT-EMRG-1400 /B

SPECIAL INSTRUCTIONS

The emergency ballast can be used with most 2' -4' lamps. Refer to the chart below for the type of lamp(s) operated and the number of lamps to be operated in emergency mode. Contact Customer Service for answers about specific lamps.

LAMP TYPE	BASE TYPE	(LENGTH) WATTAGE	NO. OF LAMPS IN EMERGENCY MODE	*BROWN LEADS
T5	Single or Bi-Pin	14W, 21W, 28W (2' - 4')	1	Connected
			2	Disconnected
		35W (5')	1	Connected
T5HO	Single or Bi-Pin	24W, 39W, 54W (2' - 4')	1	Connected
			2	Disconnected
T8	Single or Bi-Pin	17W, 25W, 28W, 32W, 40W (2' - 4')	1	Connected
			2	Disconnected
		40W (5')	1	Connected
T8HO	Single or Bi-Pin	51W, 59W (5' - 8')	1	Disconnected
		44W	1	Connected
T8HO	Single or Bi-Pin	86W (8')	1	Disconnected
T12	Single or Bi-Pin	20W, 25W, 34W, 40W (2' - 4')	1	Connected
			2	Disconnected
		30W (2' - 4')	1	Connected
		75W (5'/8')	1	Disconnected
T12HO	Single or Bi-Pin	95W, 110W, 160W, 215W (8')	1	Disconnected
Compact	G24q-1 (4-Pin), G24q-2 (4-Pin), G24q-3 (4-Pin), G24q-4 (4-Pin) G24q-5 (4-Pin)	13W, 18W, 21W, 26W, 32W, 42W, 57W	1	Connected
	G24q-1 (4-Pin), G24q-2 (4-Pin), G24q-3 (4-Pin), G24q-4 (4-Pin)	13W, 18W, 21W, 26W, 32W, 42W	2	Disconnected
Long Compact	2G11 (4-Pin)	18W, 24W, 36W, 40W, 50W	1	Connected
			2	Disconnected
		55W	1	Connected
GR10q	4-Pin	10W, 16W, 21W, 28W, 38W	1	Connected
			2	Disconnected
		55W	1	Connected
Circular T9	4-Pin	20W, 32W, 40W	1	Connected
			2	Disconnected
Circular T5	4-Pin	22W, 40W	1	Connected
			2	Disconnected
		55W	1	Connected
U-Bend T8	Bi-Pin	32W	1	Connected
			2	Disconnected
U-Bend T12	Bi-Pin	34W, 40W	1	Connected
			2	Disconnected

* The 6" brown leads provide the lamp selection option. The unit is shipped from the factory with the leads disconnected and capped.

TYPICAL WIRING DIAGRAMS.

For wiring diagrams of ballasts not shown, consult our customer service.

For One Lamp Emergency Operation

A. One (1) Lamp Instant Start AC Ballast

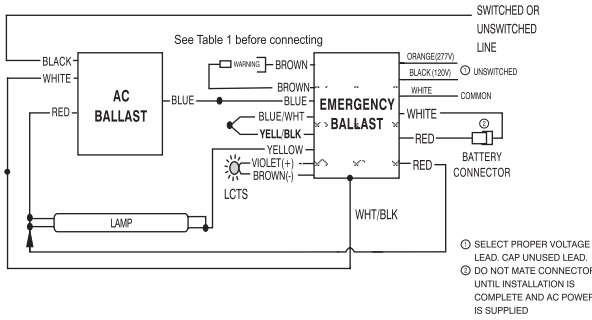

B. Two (2) Lamp Instant Start AC Ballast

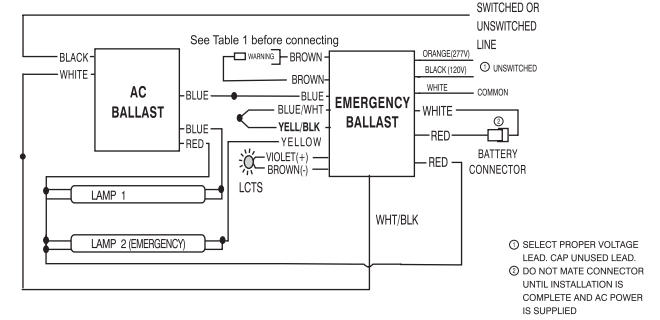

C. Three (3) Lamp Instant Start AC Ballast

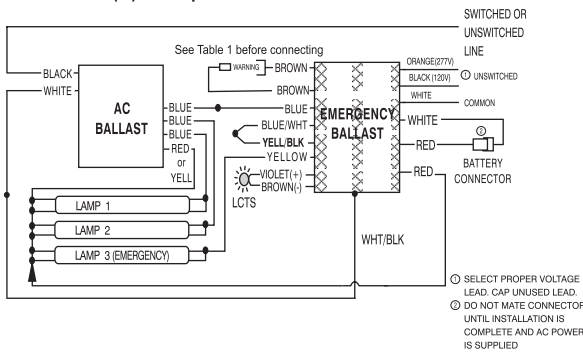

D. Four (4) Lamp Instant Start AC Ballast

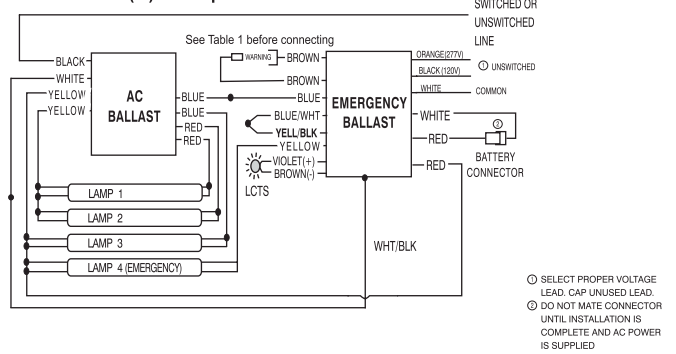

E. One (1) Lamp Rapid Start AC Ballast

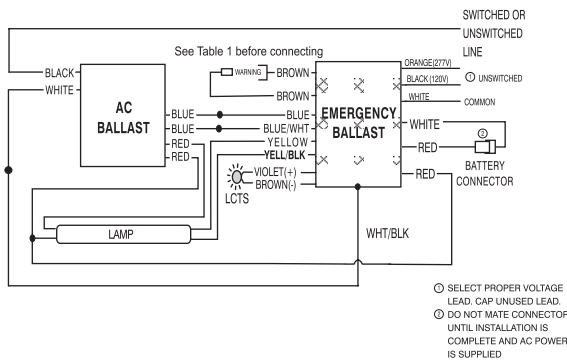

F. Two (2) Lamp Rapid Start AC Ballast

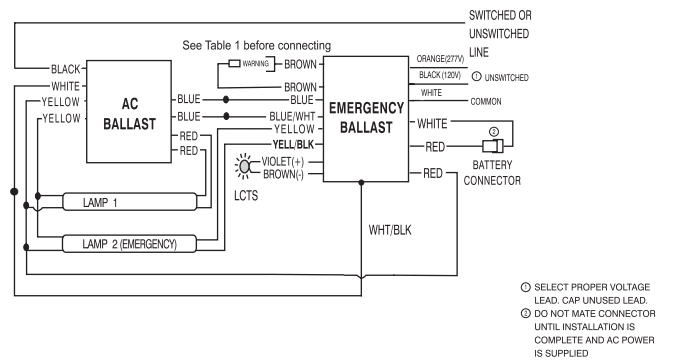

G. Three (3) Lamp Rapid Start AC Ballast

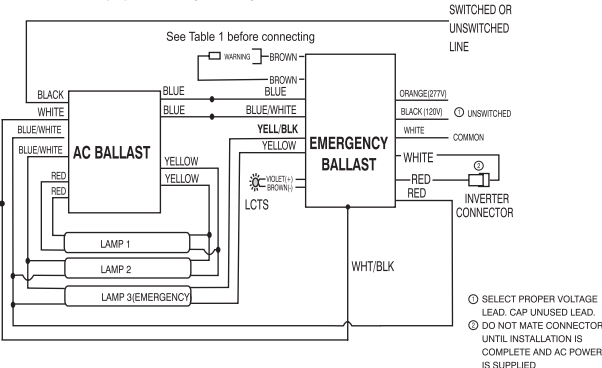

H. Four (4) Lamp Rapid Start AC Ballast

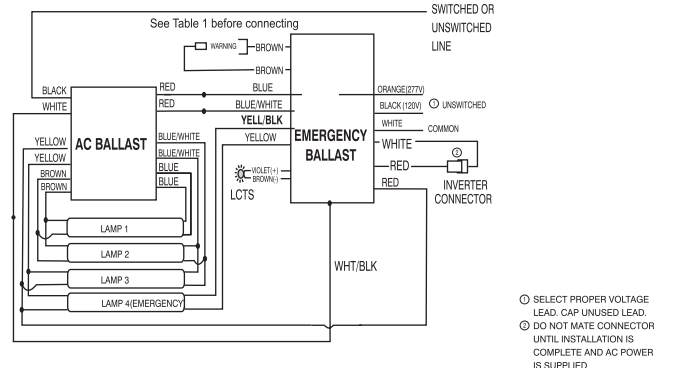

TYPICAL WIRING DIAGRAMS.

For wiring diagrams of ballasts not shown, consult our customer service.

For Two Lamp Emergency Operation

A. Two (2) Lamp Instant Start AC Ballast

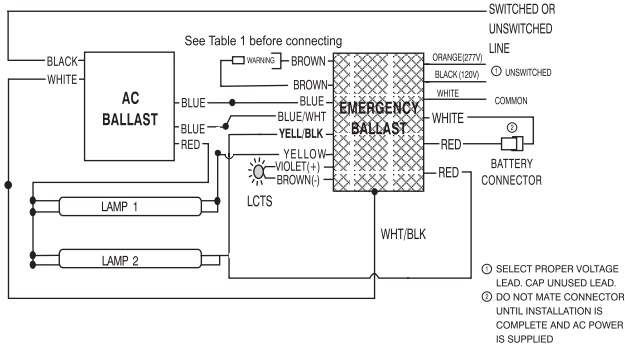

B. Three (3) Lamp Instant Start AC Ballast

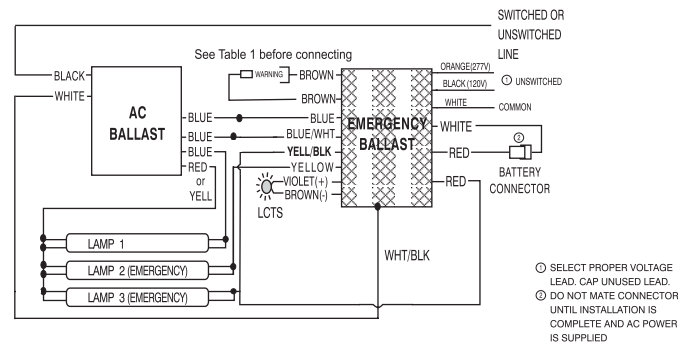

C. Four (4) Lamp Instant Start AC Ballast

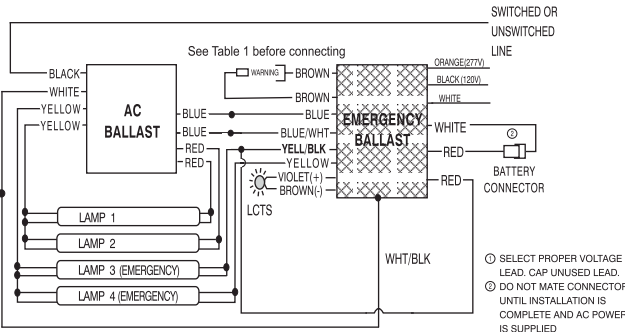

D. Two (2) Lamp Rapid Start AC Ballast

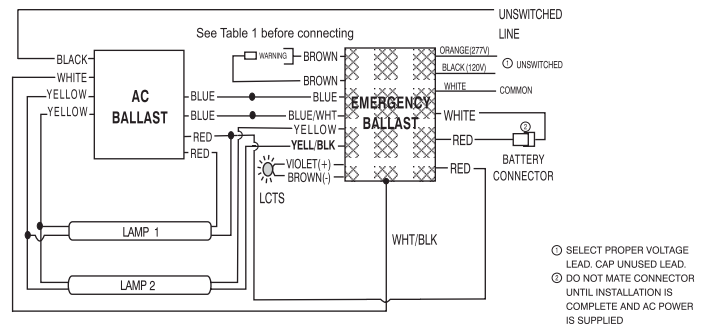

Emergency only Operation

A. One (1) Lamp Without AC Ballast

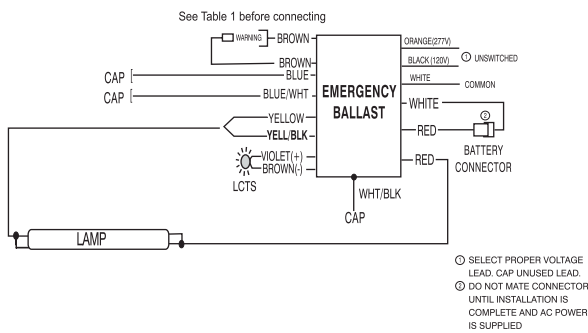

B. Two (2) Lamp Without AC Ballast

