

KT-LED7MR16-NS-9XX /G2

50W REPLACEMENT LAMP

DESCRIPTION

6.5W MR16 Lamp | 2700–5000K | ≥90 CRI | Narrow Spot Light



LAMP TYPE: MR16
BASE TYPE: GU5.3
WATTAGE: 6.5W
COLOR TEMPERATURE: 2700–5000K
COLOR RENDERING INDEX (CRI): > 90
WARRANTY: 3 Years
RATED LIFE: L70 (25,000 Hours)



TYPICAL APPLICATIONS

- Track-lighting
- Display
- Under-cabinet
- Outdoor landscaping (with suitable protection from the elements)

PRODUCT FEATURES

- Energy efficient, 80%+ energy savings over legacy equivalents
- Lower heat generation than legacy equivalents
- Smooth, uniform dimming to 10%
- Precision-crafted, full-face optics for precise beam angle control
- Durable plastic housing lowers the risk of breakage
- HiCRI LEDs offer enhanced color rendering vs. 80 CRI LEDs, providing ideal clarity, representation, uniformity of illuminated area/objects
- Long life minimizes replacement and maintenance costs
- Compatible with Keystone low voltage transformers
- Suitable for damp locations
- Operating temperature range –4°F/–20°C to 95°F/35°C
- PF: >0.9
- Rated for recessed and enclosed fixtures
- ANSI compliant construction ensures fitment for intended applications
- UL Listed
- Meets Energy Star requirements
- Complies with Part 15 of FCC
- Title 20 compliant
- Title 24 JA8 compliant (excluding 4000K and 5000K lamps)

ELECTRICAL AND PERFORMANCE SPECIFICATIONS

Keystone Catalog Number	Description	Base Type	Rated Lamp Wattage	Legacy Equivalent	CCT	Lumens	Efficacy	Input Voltage	CRI	Beam Angle	Energy Star CBCP	Dimmable
KT-LED7MR16-NS-927 /G2	MR16 narrow spot light*	GU5.3	6.5W	50W halogen	2700K	500	77 lm/W	12V	>90	25°	2942	Yes
KT-LED7MR16-NS-930 /G2	MR16 narrow spot light*	GU5.3	6.5W	50W halogen	3000K	500	77 lm/W	12V	>90	25°	3282	Yes
KT-LED7MR16-NS-940 /G2	MR16 narrow spot light*	GU5.3	6.5W	50W halogen	4000K	500	77 lm/W	12V	>90	25°	3232	Yes
KT-LED7MR16-NS-950 /G2	MR16 narrow spot light*	GU5.3	6.5W	50W halogen	5000K	500	77 lm/W	12V	>90	25°	2594	Yes

* Requires 12V transformer

KT-LED7MR16-NS-9XX /G2

REPLACEMENT LAMP

PHYSICAL CHARACTERISTICS

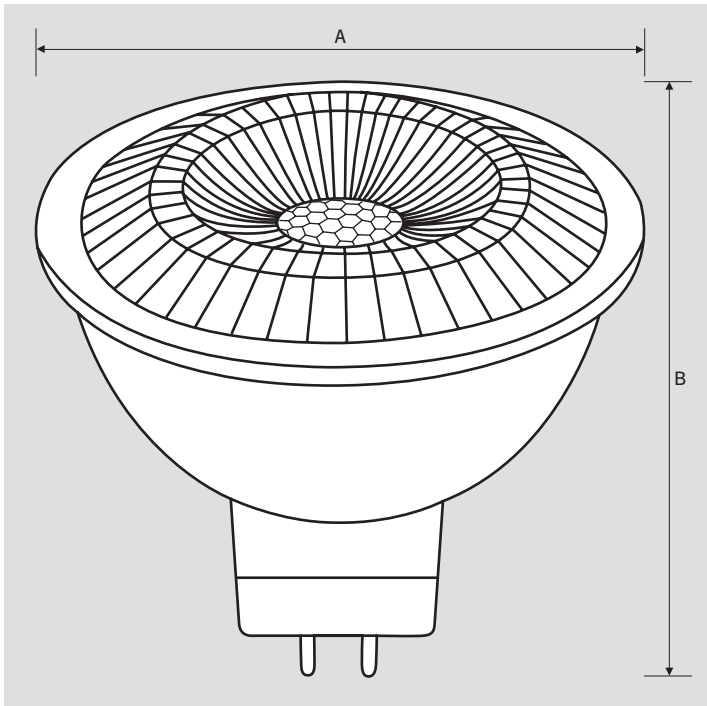

LAMP DIMENSIONS

A (Diameter)	1.97"
B (Length)	1.91"

BASE TYPE: GU5.3

RATED LIFE

L70 (Hours)	25,000
-------------	--------

PACKAGING

Carton Quantity	60 pcs
Carton Dimensions	12.95" × 10.91" × 6.54"
Carton Weight	8.6 lbs

ORDERING INFORMATION

ORDER CODE	CARTON QUANTITY	UPC	EASY CODE	ENERGY STAR UNIQUE ID
KT-LED7MR16-NS-927 /G2	60 pcs	843654141497	FXQ-09	2399238
KT-LED7MR16-NS-930 /G2	60 pcs	843654141503	KRG-38	2399239
KT-LED7MR16-NS-940 /G2	60 pcs	843654141510	PEU-50	2399240
KT-LED7MR16-NS-950 /G2	60 pcs	843654141527	KBQ-04	2400035

CATALOG NUMBER BREAKDOWN

KT-LED7MR16-NS-9XX /G2

1 2 3 4 5 6 7 8 9

- 1 Keystone Technologies
- 2 LED Lamp
- 3 Wattage
- 4 Multi-Faceted Reflector
- 5 Lamp Diameter (16/8")
- 6 Narrow Spot Light
- 7 90 CRI
- 8 CCT
- 9 Generation 2