

KT-CBLEDXPS-XXB-8CSA-VDIM CENTER BASKET LED FIXTURE RETROFIT KIT

INSTALLATION INSTRUCTIONS

PLEASE FIND A QUALIFIED ELECTRICIAN FOR INSTALLATION. Please read the instructions before installation and use.

WARNING

- To reduce the risk of death, personal injury or property damage from fire, electric shock, failing parts, cuts/abrasions, and other hazards. Read all warnings and instructions with and on the fixture box and all fixture labels.
- Before installing, servicing, or performing routine maintenance upon this equipment, follow these general precautions.
- Commercial installation, service, and maintenance of luminaires should be performed by a qualified, licensed electrician.
- For the installation: If you are unsure about the installation or maintenance of the luminaires, consult a qualified, licensed electrician and check your local electrical code.
- To prevent wiring damage or abrasion, do not expose wiring to edges of sheet metal or other sharp objects.
- Do not make or alter any open holes in an enclosure of wiring or electrical components during kit installation.

WARNING

- Turn off electrical power at fuse or circuit breaker box before wiring fixture to the power supply.
- Turn off the power when you perform any maintenance.
- Verify that supply voltage is correct by comparing it with the luminaire label information.
- All wiring connections should be capped with UL approved wire connectors.

CAUTION

- Avoid direct eye exposure to the light source while it is on.
- Account for small parts and destroy packing material, as these may be hazardous to children.
- Risk of burn. Disconnect power and allow fixture to cool before changing bulb or handling fixture.
- Note: Green ground screw provided in proper location. Do not relocate.

NOTES

- Minimum 90° supply conductors.
- Specifications and dimensions subject to change without notice.
- Suitable for dry or damp locations.

COMPONENTS INCLUDED IN KIT

Part	Quantity
LED Center Basket Fixture	1
Instruction Sheet	1

Caution: Before installing, make certain that AC power to the fixture is off.

GENERAL SETUP INSTRUCTIONS

WIRING DIAGRAM

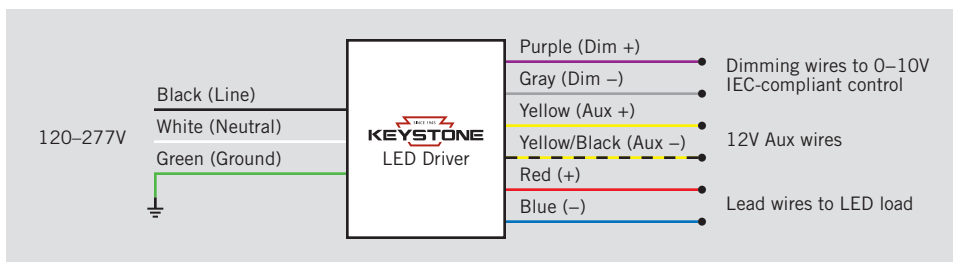

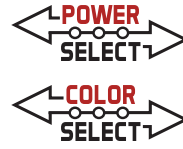

KT-CBLEDXPS-XXB-8CSA-VDIM

CENTER BASKET LED FIXTURE RETROFIT KIT

GENERAL SETUP INSTRUCTIONS (continued)

POWER SELECT (WATTAGE) AND COLOR SELECT (CCT) ADJUSTMENT

This fixture is equipped with field-adjustable Power Select and Color Select technology.

1. Ensure power is off to the fixture.
2. Adjust dip switches to desired settings.

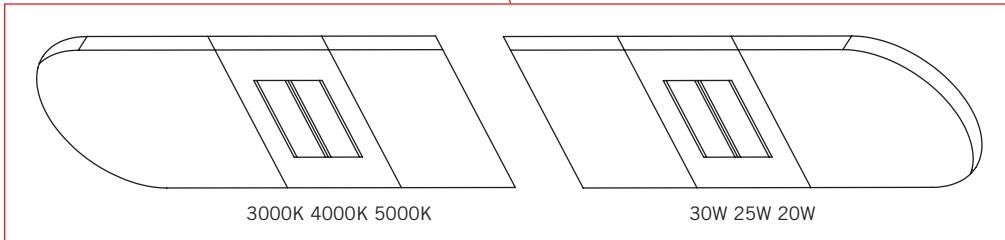
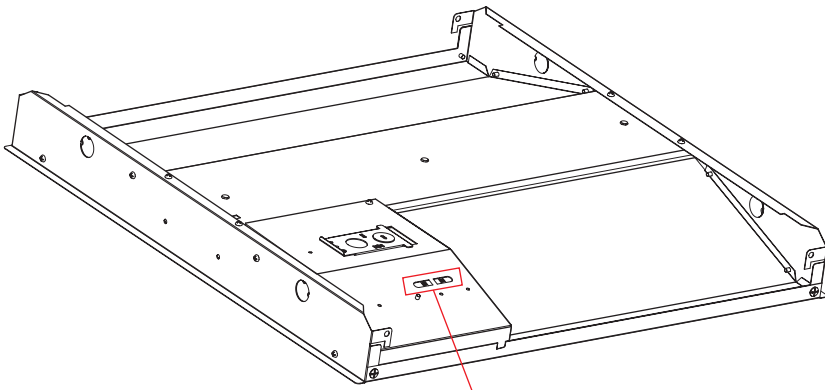

COLOR SELECT ADJUSTMENT SWITCH

Set dip switch to adjust CCT between 5000K, 4000K, and 3500K. Fixture comes preset at 5000K.

POWER SELECT ADJUSTMENT SWITCH

Set dip switch to adjust wattage.

KT-CBLEDXPS-XXB-8CSA-VDIM CENTER BASKET LED FIXTURE RETROFIT KIT

INSTALLATION

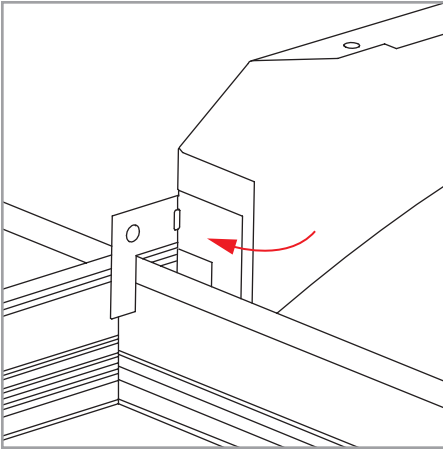

1. Ensure power is off to the fixture.
2. Bend out mounting tab 90-degrees on each corner.

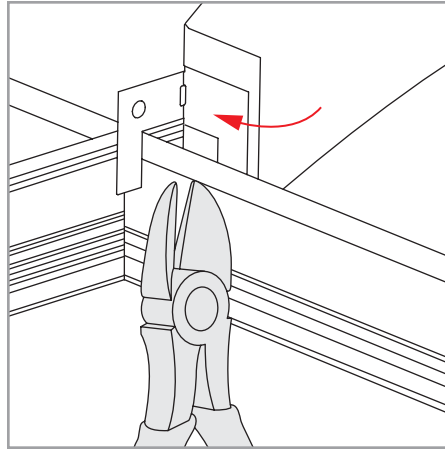

3. Use side cutters to adjust each tab to height of T-grid.

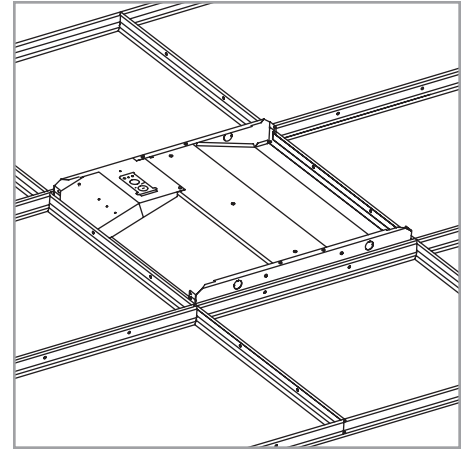

4. Lay fixture into T-grid.
5. Bend tabs flush against T-grid to clear corner for ceiling tile.

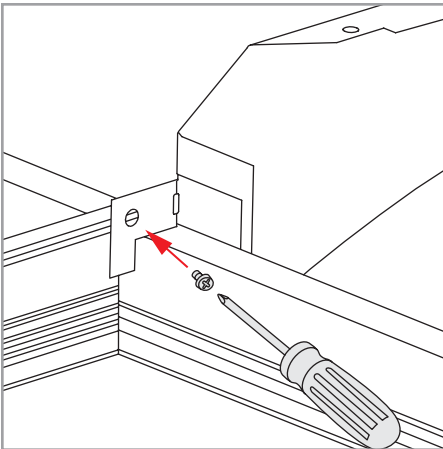

6. Use a #8 x 1/4" sheet metal screw (not supplied) to fasten fixture to T-grid.

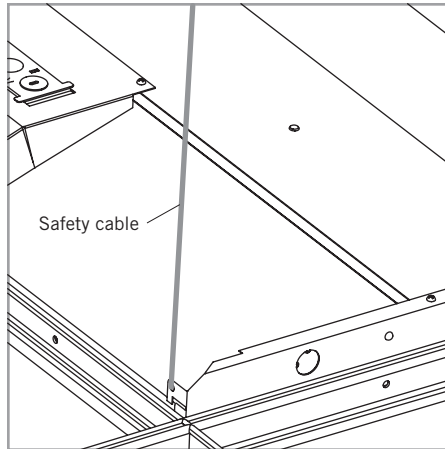

7. Use a safety cable (not supplied) to tie off in accordance with local building codes.

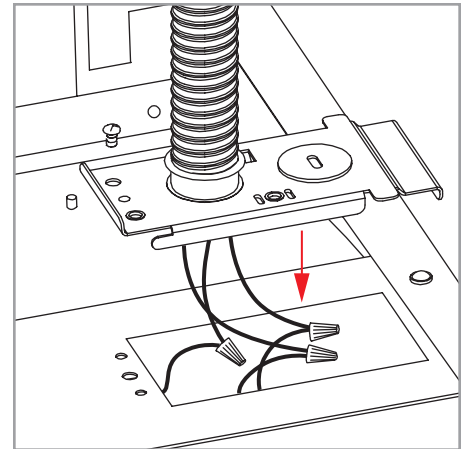

8. Ensure that the wiring of the last fixture in the row is properly terminated.
9. Make all electrical connections to the fixture.
10. Attach the wiring access cover plate.

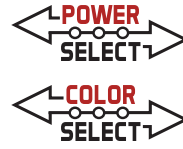

KT-CBLEDXPS-XXB-8CSA-VDIM

CENTER BASKET LED FIXTURE RETROFIT KIT

ACCESSORY (SOLD SEPARATELY)

EMERGENCY BATTERY BACKUP

Catalog Number	UPC	Easy Code
KT-EMRG-LED-5C-500	843654103099	JTR-48
KT-EMRG-LED-12C-1200	843654103112	OJQ-32

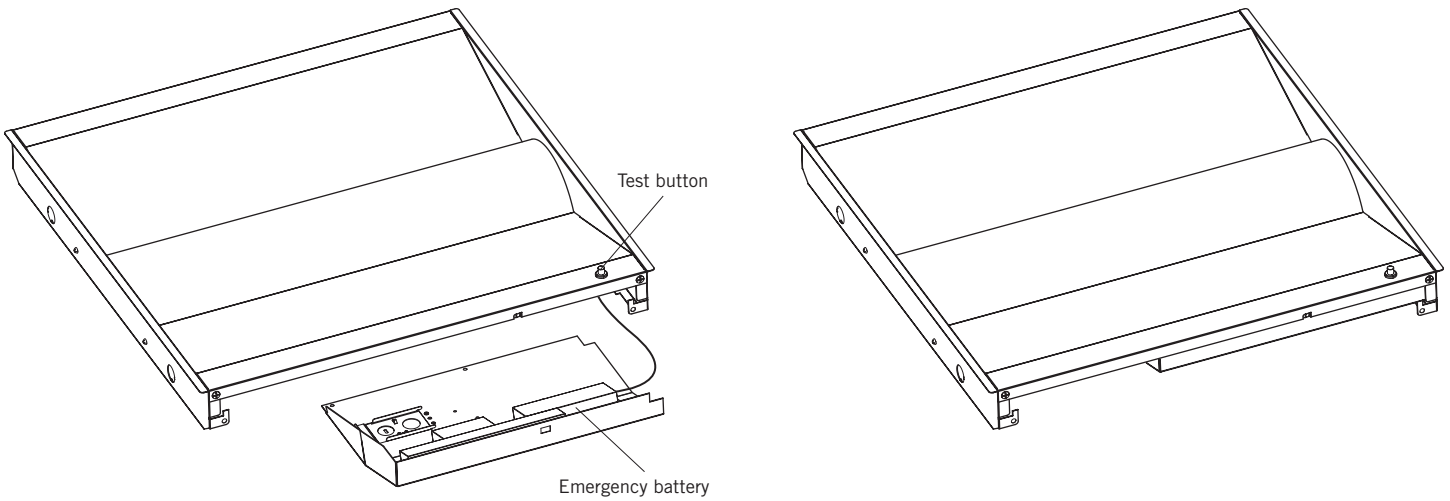

ORDERING INFORMATION

Catalog Number	PACK QTY.	UPC	Easy Code
KT-CBLE24PS-22B-8CSA-VDIM	1	843654134772	CGO-95
KT-CBLE35PS-22B-8CSA-VDIM	1	843654134789	SXT-05
KT-CBLE30PS-24B-8CSA-VDIM	1	843654134796	FLY-03
KT-CBLE45PS-24B-8CSA-VDIM	1	843654134802	TSB-09
KT-CBLE35PS-14B-8CSA-VDIM	1	843654135762	SMP-23