



XFIT | PANEL LIGHTS

POWER SELECT AND COLOR SELECT BACKLIT PANELS

INSTRUCTION MANUAL

PLEASE READ INSTRUCTIONS BEFORE COMMENCING INSTALLATION AND RETAIN FOR FUTURE REFERENCE

Electrical products can cause death, injury, or damage to property. If in any doubt about the installation or use of this product, consult a qualified electrician.

WARNING AVERTISSEMENT

CAUTION: Before installing or performing maintenance, make certain the AC power to the fixture is off.

ATTENTION: Avant d'installer ou d'effectuer une maintenance, assurez-vous que l'alimentation CA du luminaire est coupée.

CAUTION: The electrical rating of this product is 120–277V. Installer must confirm that there is 120–277V at the fixture before installation.

ATTENTION: l'alimentation électrique de ce produit est de 120 à 277 V. L'installateur doit confirmer qu'il y a de 120 à 277 V sur le luminaire avant l'installation.

- LED panels are not suitable for use in wet locations.
- Les panneaux LED ne conviennent pas pour une utilisation dans des endroits humides.
- Please keep the LED panel away from any corrosive substance, and please use dry cloth when you clean it.
- Veuillez éloigner le panneau LED de toute substance corrosive et utiliser un chiffon sec pour le nettoyer.
- LED panel can only be installed by a qualified electrician.
- Le panneau LED ne peut être installé que par un électricien qualifié.
- Risk of electrical shock. Do not open or remove covers.
- Risque de choc électrique. N'ouvrez pas et ne retirez pas les capots.
- Use in dry or damp locations only. Not for use where exposed to weather.
- Utiliser uniquement dans des endroits secs ou humides. Ne pas utiliser en cas d'exposition aux intempéries.

IMPORTANT

- Read instructions carefully before installation.
- Lisez attentivement les instructions avant l'installation.
- Keep these instructions for future reference.
- Conservez ces instructions pour référence future.
- The backlit LED panels must be wired in accordance with the National Electrical Code and all applicable local codes.
- Les panneaux LED rétroéclairés doivent être câblés conformément au Code national de l'électricité et à tous les codes locaux applicables.
- Proper grounding is required for safety.
- Une mise à la terre appropriée est requise pour la sécurité.

CAUTION

- Inherently protected.
- Intrinsèquement protégé.
- Access above ceiling required.
- Accès au-dessus du plafond requis.
- Suitable for operation in ambient not exceeding 104°F.
- Convient pour un fonctionnement dans une température ambiante ne dépassant pas 104°F.
- Do not press the diffuser with your fingers (when installing the panel light).
- N'appuyez pas sur le diffuseur avec vos doigts (lors de l'installation du panneau lumineux).

STANDARD PANELS

Fixture Size	Catalog No.	Color Temp.	Power	Input Voltage	Luminous Efficacy	Luminous Flux	CRI	Power Factor	Dimming
1' x 4'	KT-BPLED40PS-14-8CSA-VDIM /G2	3500K	40W	120 -277Vac	110 lm/W	4400 lm	> 80	> 0.9	0 -10V
		4000K	30W			3300 lm			
		5000K	20W			2200 lm			
2' x 4'	KT-BPLED50PS-24-8CSA-VDIM /G2	3500K	50W	120 -277Vac	110 lm/W	5500 lm	> 80	> 0.9	0 -10V
		4000K	40W			4400 lm			
		5000K	30W			3300 lm			
2' x 2'	KT-BPLED40PS-22-8CSA-VDIM /G2	3500K	40W	120 -277Vac	110 lm/W	4400 lm	> 80	> 0.9	0 -10V
		4000K	30W			3300 lm			
		5000K	20W			2200 lm			

NOTE: Panel comes preset at 5000K and highest wattage.
 To adjust color temperature use the switch labelled "3500K / 4000K / 5000K"
 To adjust lumen output, use switch on back of the panel labelled "20W / 30W / 40W"
 or "30W / 40W / 50W"

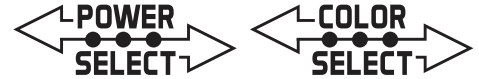

INSTALLATION GUIDE

1. Remove the original ceiling tile for the Backlit LED Panel.

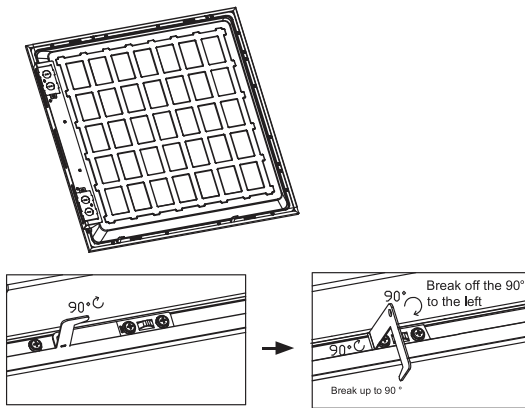

2. Turn off the electrical power then connect with Line (L), Neutral (N) and Ground (GND) wire leads.

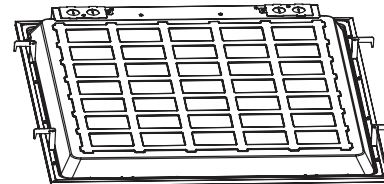

3. Use the protective brackets for safety.

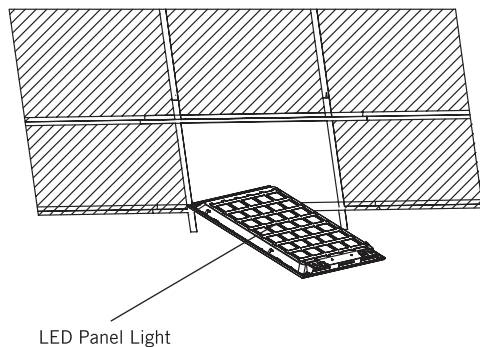

4. Adjust appropriate location in the T Bar.

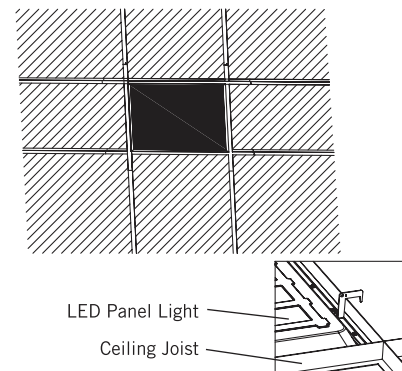

SURFACE MOUNT KIT INSTALLATION (SOLD SEPARATELY)

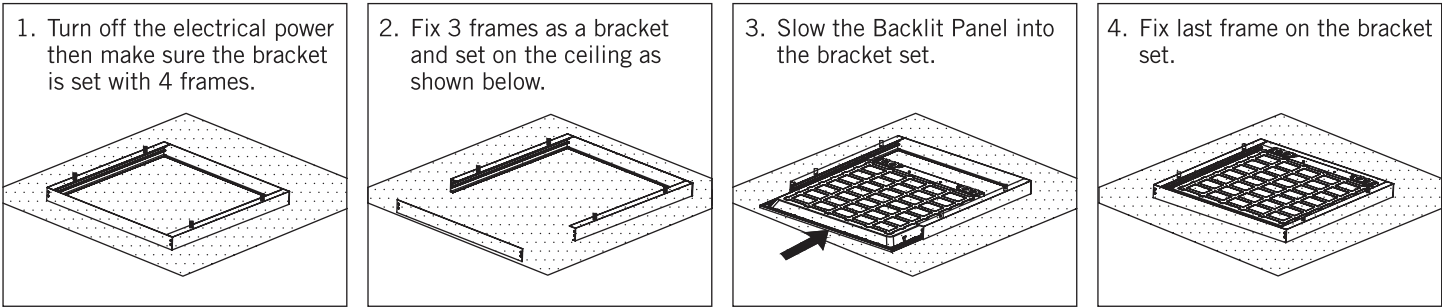

WIRE CONNECTION

