

INSTALLATION AND OPERATING INSTRUCTIONS FOR THE FOLLOWING PRODUCTS:

CAT. NO. KT-EMRG-LED-5-500-EN /DF CAT. NO. KT-EMRG-LED-12-1200-EN /DF

## INSTALLATION

Product includes the following components:

PARTS	QUANTITY
LED Emergency Driver	1
Instruction Sheet	1
Luminaire Modification Label	1
Test Button	1
Switch Plate Cover	1

**Note:** Install requires application of the Luminaire Modification Label provided, as per UL. This label includes the statement: "This equipment has more than one power supply connection point." This label must be applied to the fixture housing during installation.

## IMPORTANT SAFEGUARDS

When using electrical equipment, basic safety precautions should always be followed including:

### READ AND FOLLOW ALL SAFETY INSTRUCTIONS

**WARNING:** Risk of fire or electric shock. Luminaire wiring and electrical parts may be damaged when drilling for installation of LED Emergency Backup. Check for enclosed wiring and components.

**WARNING:** Risk of fire or electric shock. This LED Emergency Backup installation requires knowledge of luminaires electrical systems. If not qualified, do not attempt installation. Contact a qualified electrician.

**WARNING:** Risk of fire or electric shock LED Emergency Backup is only for use in surface mount or recessed Type IC or Non-IC luminaires listed to UL Standards. Suitable for use in damp locations and plenum spaces. Not for use in heated air outlets or hazardous locations.

**WARNING:** Risk of fire or electric shock. Do not alter, relocate, or remove wiring, lampholders, power supply, or any other electrical component.

**WARNING:** To prevent wiring damage or abrasion, do not expose wiring to edges of sheet metal or other sharp objects.

**WARNING:** Do not make or alter any open holes of the wiring enclosure or electrical component enclosure during installation. Only those open holes indicated in the instructions and/or drawings may be added or altered as a result of LED Emergency Backup installation. Do not leave any other open holes in the wiring enclosure or electrical component enclosure during installation.

**CAUTION:** Before installing, make certain the AC power to the fixture is off.

**CAUTION:** The electrical rating of this product is 120-277V. Installer must confirm that there is 120- 277V at the fixture before installation.

**CAUTION:** To prevent electrical shock, only mate unit connector after installation is complete and before the AC power to the fixture is back on.

**CAUTION:** This fixture provides more than one power supply output source. To prevent electrical shock, disconnect both normal and emergency sources by turning off the AC branch circuit and disconnecting the unit connector.

**CAUTION:** This is a sealed unit. Components are not replaceable. Replace the entire LED Emergency Backup unit when necessary.

Do not use outdoors.

This LED Emergency Backup unit requires an unswitched AC power source of 120-277V, 50/60 Hz. The AC driver MUST be on the same branch circuit as the LED Emergency Backup unit.

Do not let power supply cords touch hot surfaces.

Do not mount near gas or electric heaters.

Install in accordance with the National Electrical Code and local regulations.

Equipment should be mounted in locations and at heights where it will not readily be subjected to tampering by unauthorized personnel.

The use of accessory equipment not recommended by the manufacturer may cause an unsafe condition.

Do not use this equipment for other than intended use.

Use with grounded, UL Listed, damp location rated fixtures. Case should also be grounded.

The equipment is intended for ordinary locations and for permanent installation into one or more listed emergency luminaires.

## SAVE THESE INSTRUCTIONS

# INSTALLATION

1. Read and understand all warning and notes stated above, before proceeding with installation.

## 2. Fixture Compatibility & Applications

The KT-EMRG-5-500-EN /DF and KT-EMRG-12-1200-EN /DF emergency packs can be used with most LED loads that have a forward voltage requirement between 20-54Vdc. Verify AC driver in the fixture is Class 2 compliant per driver manufacturer specifications. Verify LED load has a forward voltage requirement between 20-54Vdc. Confirm that the Emergency Pack selected does not exceed the power delivered to the LED load under normal operation from the AC driver.

These emergency packs have been evaluated to and found compliant to UL 924. The emergency pack assembly is accepted as a component of a luminaire where the suitability of the combination shall be determined by UL or Authorities Having Jurisdiction. The as-installed performance of the system must meet or exceed all Federal, State, and Local code requirements.

## Specification Chart

Catalog No.	Rated Output Power <sup>1</sup>	Nominal Lumen Output <sup>2</sup>
KT-EMRG-LED-5-500-EN /DF	4.6W (Constant)	460 Lumens
KT-EMRG-LED-12-1200-EN /DF	10.6W (Constant)	1060 Lumens

<sup>1</sup>Rated Output Power based on worse case performance at 0°C.

<sup>2</sup>Nominal lumen output is based on a standard LED fixture rated efficacy (lumens per watt, lm/W) of 100 lm/W.

Multiply lm/W by Rated Output Power of emergency pack to determine lumen output of fixture during emergency operation.

To calculate actual minimum lumen output of fixture under emergency operation:

- Determine the fixture efficacy under normal AC operation, based on fixture manufacturer published data, in lumens per watt (lm/w).
  - Reference DLC QPL ([www.designlights.org](http://www.designlights.org)) for rated data on fixture efficacy. If fixture is not found on DLC QPL, contact fixture manufacturer.
- Multiply fixture lm/w by rated output power of emergency pack. (Example: 104 lm/w x 4.6W = 478.4 lumens.)

## 3. Determining Adequacy of Means-of-Egress Lighting Levels

Follow industry standards by utilizing available .ies files and lighting design software for your dedicated emergency luminaires, with the above calculated emergency lumens, and validate your as-installed plans in accordance with the applicable life safety codes governing your project.

While these products are compliant with the requirements of UL Standard 924, it is ultimately the responsibility of the designer/specifier to assure the as-installed system delivers code compliant path of egress illumination in accordance with federal, state or local municipal requirements.

## 4. Mounting

Mount the LED Emergency Backup unit on or adjacent to the existing fixture in a position that does not interfere with the fixture, its components, or any other hardware. Extend the Flex Conduit A (see Figure 1) to the junction box or wireway channel using the existing knockout (or punch hole as needed). Feed the wires and flex connector through the knockout and secure in place.

Consult Keystone's customer service (800-464-2680) for the maximum allowable distance between the battery pack and the load when the battery pack is being remotely mounted.

To install the test button, cut a single gang switch box into the ceiling tile adjacent to the fixture withing reach of Flex Conduit B. After mounting the switch box, connect Flex Conduit B to the box and route all leads inside the box. This box will also contain the battery pack connectors. Do not connect until install in complete and AC power is restored. Refer to Figure 1 for typical mounting. For proper operation, use only the accessory components provided with the unit.

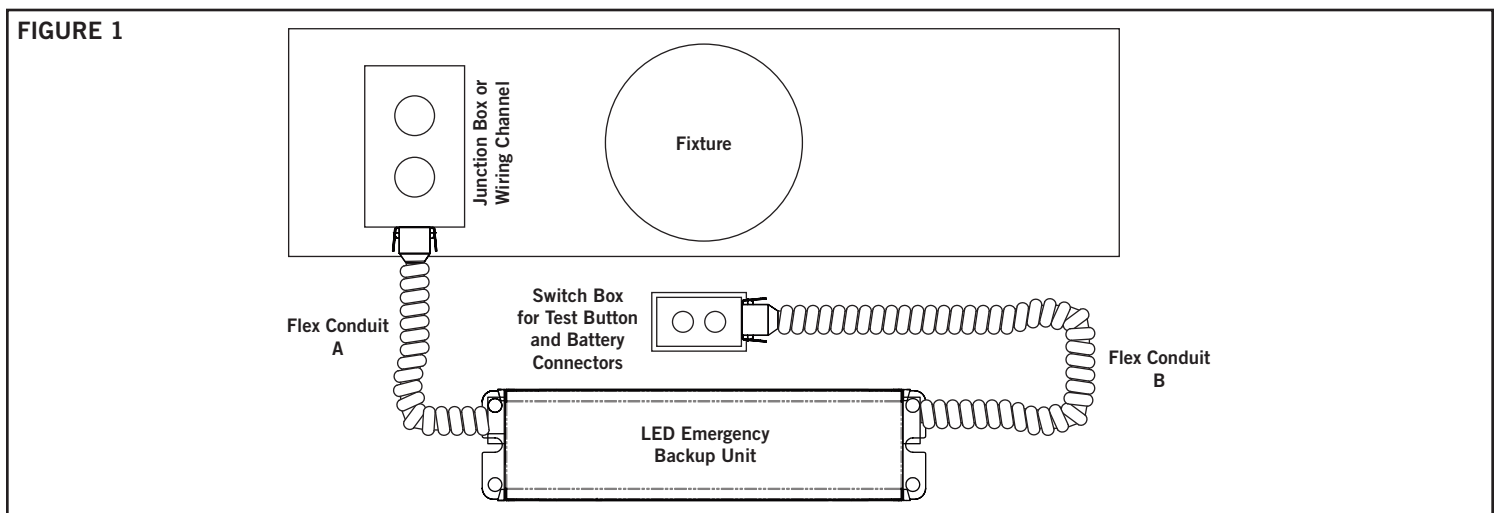

## 5. Wiring & Labeling

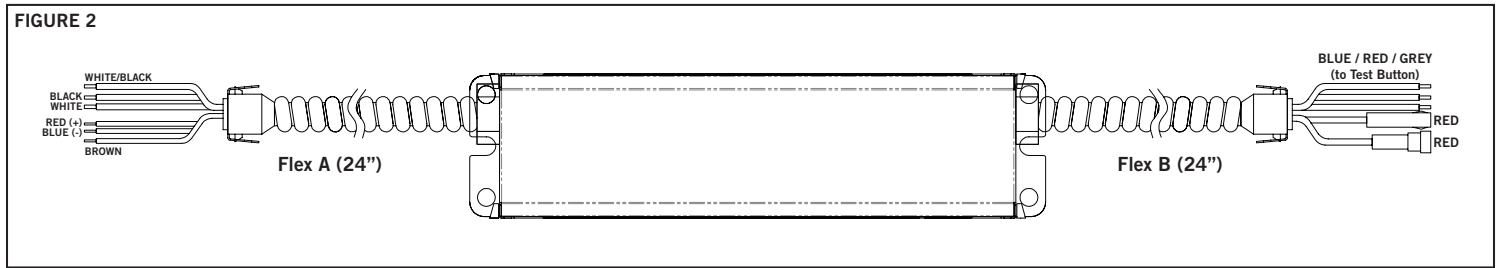

Complete wiring as indicated below. Install in accordance with National Electric Code. Emergency Pack and AC Driver must be on the same branch circuit. Ensure hot / live lead going to the black wire on the Emergency LED driver is Un-Switched. When used with switched fixtures, the emergency pack must be wired ahead of the switch. (See Figure 3.)

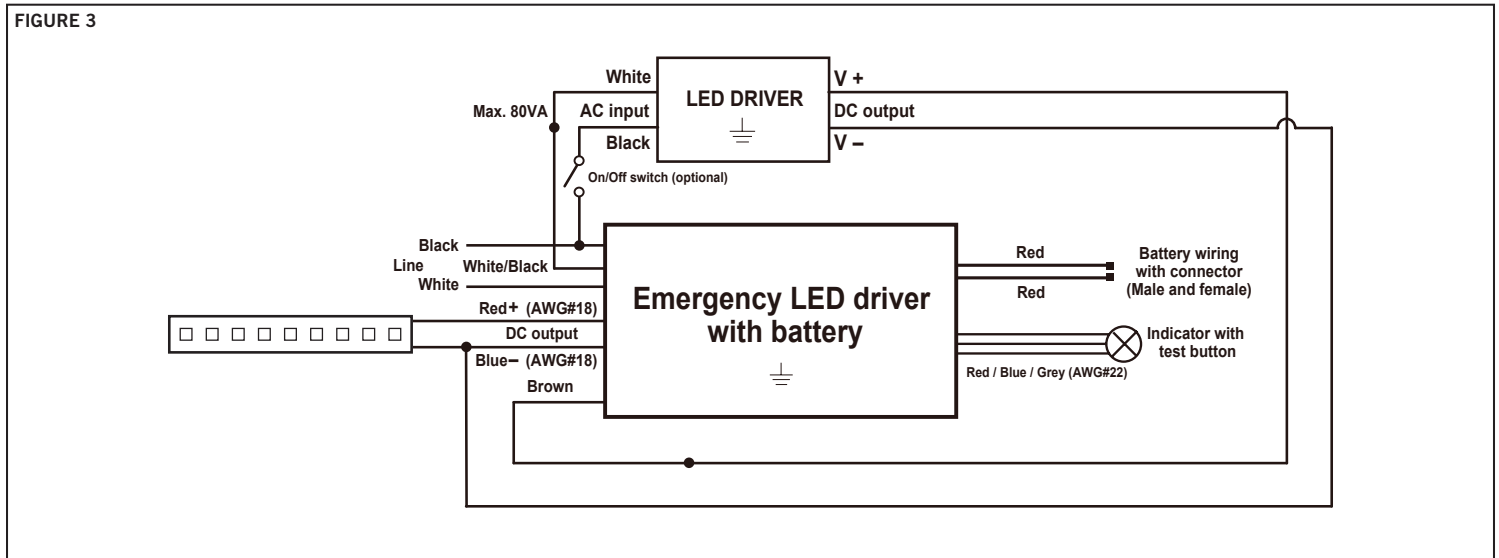

Adhere Luminaire Modification Label to the fixture on the ballast cover where it is easily visible to anyone servicing the fixture in the future.

## 6. Complete Installation

When the installation is complete, verify all necessary connections have been made. Switch the AC Power on and join the battery pack connector.

## 7. Operation

**Normal Mode:** AC power is present. The AC driver operates the LED load as designed. The emergency pack is charging in a standby mode. The test button will be lit, showing that the battery is charging. The test button will stay lit even when fully charged.

**Emergency Mode:** When the AC power goes out, the emergency pack detects the power outage and automatically switches to the emergency mode. The LED load is illuminated, for a minimum of 90 minutes. The test button will not be lit. When AC power is restored, the emergency pack switches back to Normal Mode and starts re-charging. If emergency driver detects battery failure, such as bad contact or charging issues, the test button will not be lit. Please contact a qualified electrician for inspection.

## 8. Testing Procedures

Press the test button to cut the power to the AC driver and switch the system to emergency mode. Release the test button to return to normal mode. Switch off the circuit breaker to simulate a full power outage. For Initial Testing, allow the unit to charge approximately 1 hour, then conduct a short discharge test. Allow a 24 hour charge before conducting a one hour test.

NFPA 101, Life Safety Code outlines the following schedule:

**Monthly** - Insure that the test button light is illuminated. Conduct a 30 second discharge test by depressing the test button. The LED load should operate at reduced output.

**Annually** - Insure that the test button is illuminated. Conduct a full 90 minute discharge test. The unit should operate as intended for the duration of the test.

“Written records of the testing shall be kept by the owner for inspection by the authority having jurisdiction.”