

KT-RDLED20PS-8A-9CSE-VDIM-EM5

8" RECESSED EMERGENCY DOWNLIGHT

DESCRIPTION

8" Recessed Emergency Downlight |
 Power Select Technology (20W; 17W; 14W) |
 Color Select Technology (3000K; 3500K; 4000K) |
 Built-In 5W Emergency Pack

APPLICATION

Ideal for hospitality, retail, office, and other retrofit and new construction applications

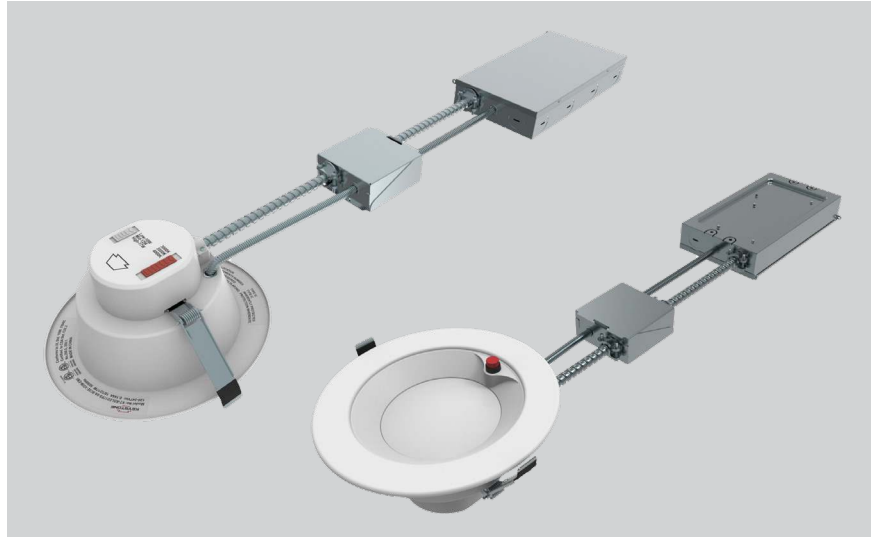

PRODUCT FEATURES

- Complete, pre-wired emergency downlight solution—including test button—removes all typical guesswork, uncertainty, and complex installation issues from battery backup downlight applications
- Keystone Power Select and Color Select technologies offer SKU reduction and allow for easy, on-the-job adjustments
- Built-in 5W LED Keystone SmartSafe emergency driver that is compliant with CEC T20
- Battery uses LifePO4 technology
- Designed with junction box and quick disconnects for easy installation
- Ideal for new construction, remodeling, and retrofit applications
- Smooth reflector trim offers clean, modern appearance
- Diffused lens reduces glare
- Interchangeable trims available in matte black, brushed nickel, and bronze
- Powered by Keystone 0–10V dimming LED driver; 10–100% dimming
- Ambient operating temperature: 0°C/32°F to 40°C/104°F
- Suitable for use in dry and damp locations
- Airtight and Type IC-rated
- Power Factor: >0.90
- THD: <20%
- LED chip lifetime: L70 >80,000 hrs @ 25C°/77F° ambient fixture temp
- FCC Part 15, Subpart B, Class A

PERFORMANCE SPECIFICATIONS

Catalog Number	Input Voltage	Wattage (Selectable)	CCT (Selectable)*	Lumen Output	Efficacy	Emergency Wattage	Emergency Lumen Output	CRI	Power Factor	Lifetime
KT-RDLED20PS-8A-9CSE-VDIM-EM5	120–277V	20W	3000K	1580	79 lm/W	5W	500	>90	>0.9	50,000 hrs
			3500K	1680	84 lm/W					
			4000K	1650	83 lm/W					
		17W	3000K	1300	76 lm/W					
			3500K	1380	81 lm/W					
			4000K	1350	79 lm/W					
		14W	3000K	1080	77 lm/W					
			3500K	1150	82 lm/W					
			4000K	1120	80 lm/W					

* Preset to highest CCT: 4000K
 Color Uniformity: CCT (Correlated Color Temperature) range as per guidelines outlined in ANSI C78.377-2017

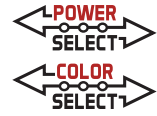

KT-RDLED20PS-8A-9CSE-VDIM-EM5

8" RECESSED EMERGENCY DOWNLIGHT

PHOTOMETRIC SPECIFICATIONS

POLAR CANDELA DISTRIBUTION

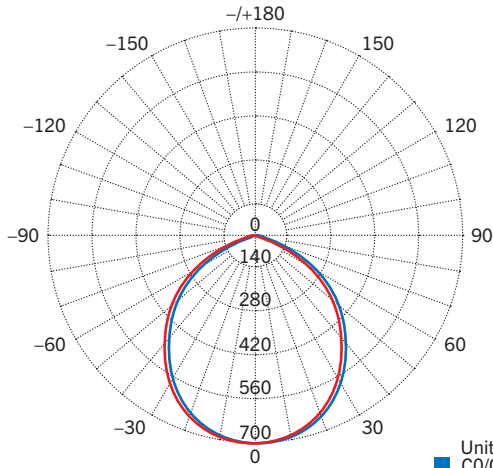

Average Beam Angle (50%): 106.5°

Unit: cd
 C0/C180: 52.9; 53.5
 C90/C270: 54.3; 52.2

ZONAL LUMEN SUMMARY

Zone	Lumens	% Luminaire
0°-30°	532.6	30.0%
0°-40°	863.5	48.6%
0°-60°	1,492.1	84.0%
60°-90°	284.9	16.0%
70°-100°	87.4	4.9%
90°-120°	0.0	0%
0°-90°	1,777.0	100%
90°-180°	0.0	0%
0°-180°	1,777.0	100%

PHYSICAL SPECIFICATIONS

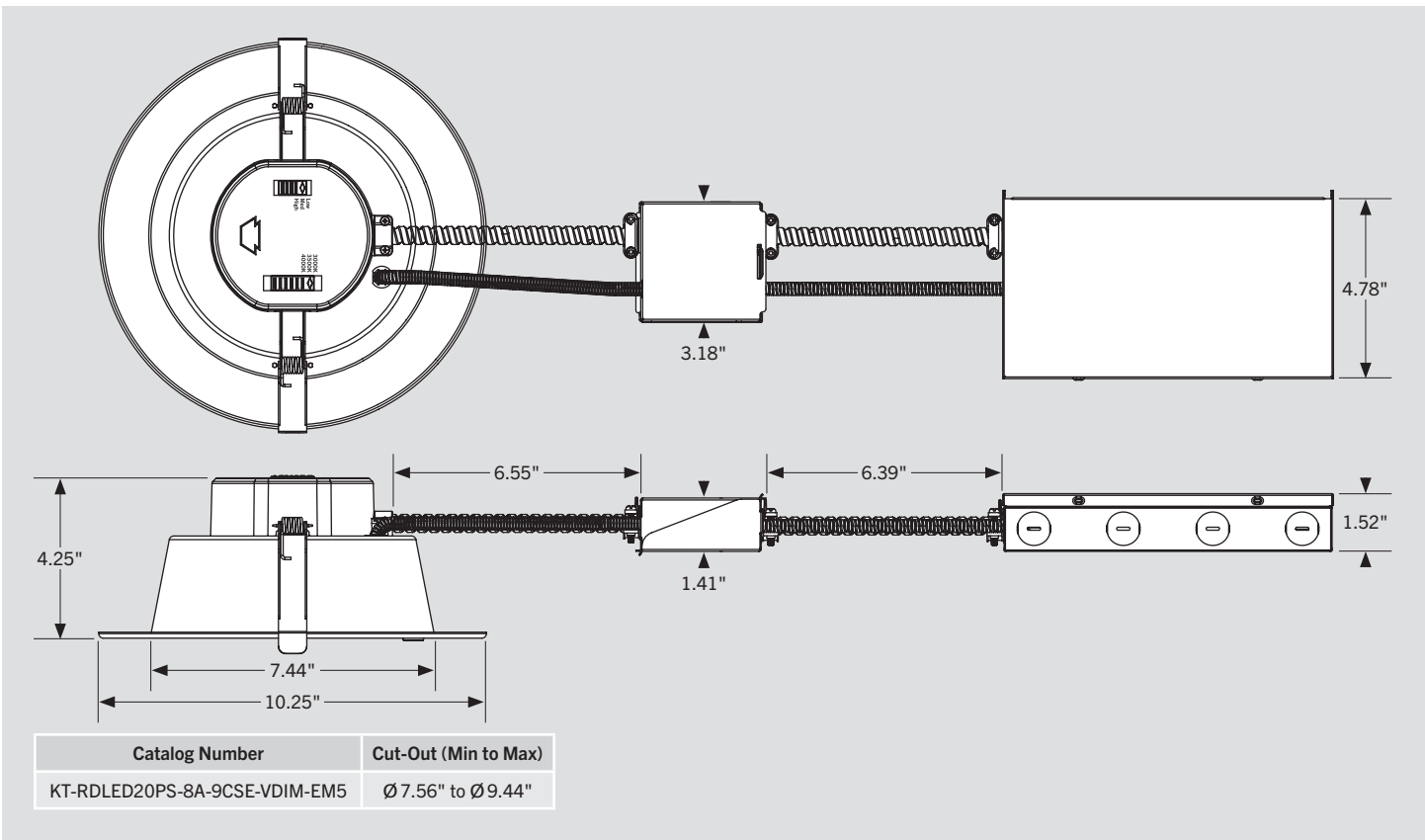

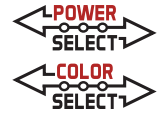

KT-RDLED20PS-8A-9CSE-VDIM-EM5 8" RECESSED EMERGENCY DOWNLIGHT

POWER SELECT (WATTAGE) AND COLOR SELECT (CCT) ADJUSTMENT

This fixture is equipped with field-adjustable Keystone Power Select and Color Select technology.

1. Ensure power is off to the fixture.
2. Adjust dip switches to desired setting

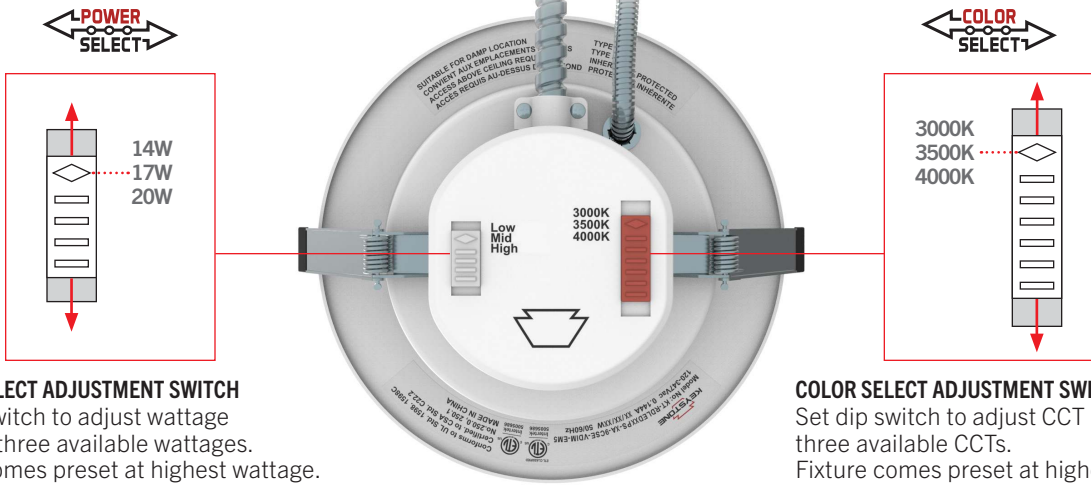

POWER SELECT ADJUSTMENT SWITCH
Set dip switch to adjust wattage between three available wattages. Fixture comes preset at highest wattage.

COLOR SELECT ADJUSTMENT SWITCH
Set dip switch to adjust CCT between three available CCTs. Fixture comes preset at highest CCT.

WIRING DIAGRAM

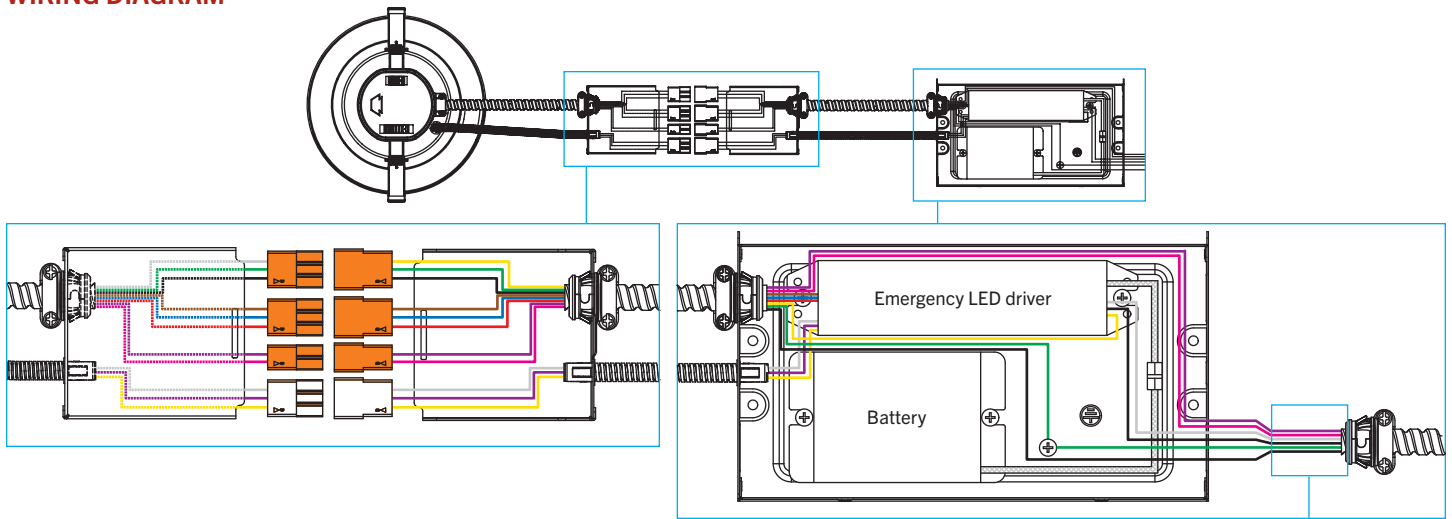

Note: Install in accordance with National Electric Code. Emergency pack and fixture driver must be on the same branch circuit. Ensure hot/live lead going to the black wire on the emergency LED driver is unswitched. When used with switched fixtures, the emergency pack must be wired ahead of the switch.

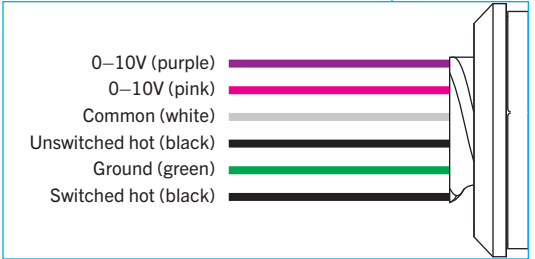

KT-RDLED20PS-8A-9CSE-VDIM-EM5 8" RECESSED EMERGENCY DOWNLIGHT

INSTALLATION INSTRUCTIONS*

- 1. Shut off power at the source of the fixture housing into which you are installing fixture.**

If retrofit, remove existing trim, CFL/ incandescent bulb, and ballast/ emergency ballast.

Note: Follow all federal and local regulations when disposing of lamps and removed components.

- 2. Use template to cut appropriate sized hole in ceiling for fixture.**

If retrofit, measure existing ceiling opening to ensure that the edge of the luminaire will cover the entire opening and still sit firmly in the ceiling (see *Dimensions* on page 2).

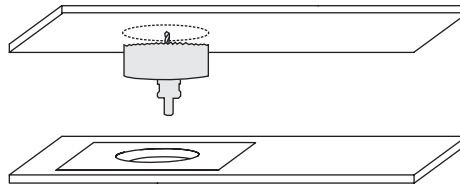

- 3. Select desired Wattage and CCT using adjustment switches on fixture (see *Power Select (Wattage) and Color Select (CCT) Adjustment* on page 3).**

- 4. Attach safety clip to structural point above plenum.**

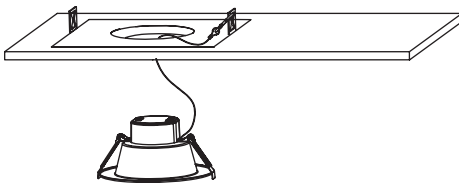

- 5. Insert J-box with EM pack into ceiling and wire to power source. Install in accordance with local and national codes. (See *Wiring Diagram* on page 3). Close J-box cover when done.**

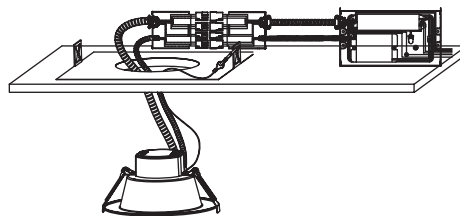

- 6. Push connectors from downlight together with connectors from emergency pack J-box. Note that each connector is keyed to fit only with its corresponding counterpart. Snap connector box together to close.**

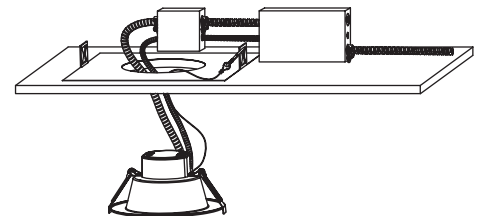

- 7. Squeeze the two housing clips so they are in an upright position and then insert lamp into housing.**

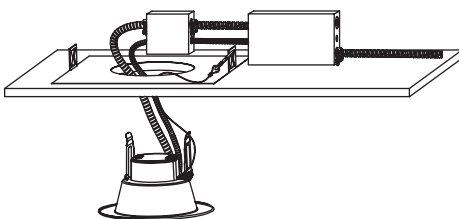

- 8. Once lamp is inside housing, release housing clips and continue to push lamp into housing until securely fixed and flush with ceiling. Restore power.**

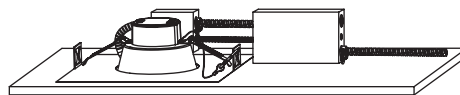

* Keystone offers an optional new-construction plate for both new joist and T-grid installations. See *Optional Accessories (sold separately)* on page 6.



ADVANTA_{EMRG}



KT-RDLED20PS-8A-9CSE-VDIM-EM5 8" RECESSED EMERGENCY DOWNLIGHT

OPERATION

NORMAL MODE

- AC power is present.
- The AC driver operates the LED load as designed.
- The emergency pack is charging in a standby mode.
- The test button will be lit, showing that the battery is charging.
- When battery is fully charged, test button will remain lit.

EMERGENCY MODE

- When the AC power goes out, the emergency pack detects the power outage and automatically switches to the emergency mode.
- The LED load is illuminated for a minimum of 90 minutes.
- The test button will not be lit.
- When AC power is restored, the emergency pack switches back to normal mode and starts re-charging.
- If emergency driver detects battery failure due to problems such as bad contact or charging issues, the test button will not be lit.
- Please contact a qualified electrician for inspection.

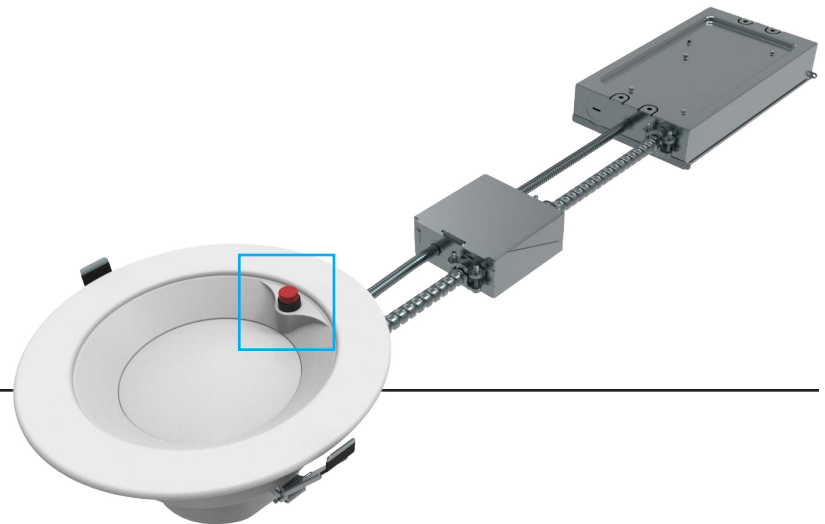

TESTING PROCEDURES

1. Press the test button to cut the power to the AC driver and switch the system to emergency mode.
2. Release the test button to return to normal mode.
3. Switch off the circuit breaker to simulate a full power outage.
4. For initial testing, allow the unit to charge for approximately one (1) hour, then conduct a short discharge test.
5. Allow a 24-hour charge before conducting a one-hour test.

ROUTINE TESTING SCHEDULE

NFPA 101, Life Safety Code outlines the following schedule:

Monthly

1. Ensure that the test button light is illuminated.
2. Conduct a 30-second discharge test by depressing the test button.
3. The LED load should operate at reduced output.

Annually

1. Ensure that the test button is illuminated.
2. Conduct a full 90-minute discharge test.
3. The unit should operate as intended for the duration of the test.

"Written records of the testing shall be kept by the owner for inspection by the authority having jurisdiction."

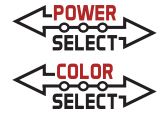

KT-RDLED20PS-8A-9CSE-VDIM-EM5

8" RECESSED EMERGENCY DOWNLIGHT

OPTIONAL ACCESSORIES (sold separately)

INTERCHANGEABLE TRIM

Catalog Number	Description	UPC	Easy Code
KT-RDLED-EM-8A-MB-TRIM	8" Interchangeable trim for 8" recessed emergency downlights; Matte black	843654137346	TVP-14
KT-RDLED-EM-8A-BN-TRIM	8" Interchangeable trim for 8" recessed emergency downlights; Brushed nickel	843654137360	YER-50
KT-RDLED-EM-8A-BR-TRIM	8" Interchangeable trim for 8" recessed emergency downlights; Bronze	843654137384	QRQ-01

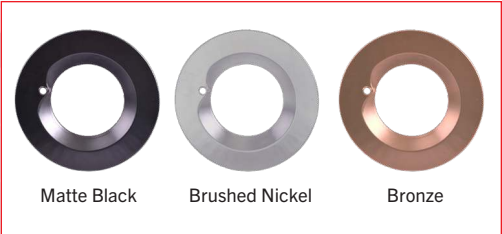

GOOF RING

Catalog Number	Description	UPC	Easy Code
KT-RDLED-8A-GOOF	8" Goof ring for 8" recessed emergency downlights; 12.51" outer diameter	843654137254	UDK-67

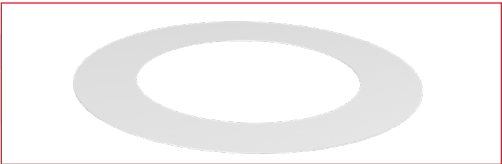

NEW-CONSTRUCTION PLATE

Catalog Number	Description	UPC	Easy Code
KT-RDLED-PLATE-1	New-construction plate for recessed emergency downlights	843654137285	BMS-81

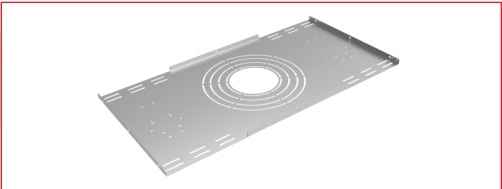

ORDERING INFORMATION

Catalog Number	Pack Qty.	UPC	Easy Code
KT-RDLED20PS-8A-9CSE-VDIM-EM5	1	843654137315	TZD-27

CATALOG NUMBER BREAKDOWN

KT-RDLED20PS-8A-9CSE-VDIM-EM5

1 2 3 4 5 6 7 8 9 10 11 12 13

- 1** Keystone Technologies
- 2** Fixture Type

RD	Recessed Downlight
----	--------------------
- 3** LED Technology
- 4** Maximum Wattage
- 5** Power Select Technology
- 6** Size

8	8" Nominal
---	------------
- 7** Style/Design Designation

A	Series A
---	----------
- 8** CRI
- 9** Color Select Technology
- 10** Color Select Designation

E	3000K, 3500K, 4000K
---	---------------------
- 11** Dimming

VDIM	0-10V Dimming
------	---------------
- 12** Emergency Pack
- 13** Emergency Pack Wattage

EM	Built-in Emergency Pack	5	5W
----	-------------------------	---	----