

KT-EMRG-750-CFL4 /B

FLUORESCENT EMERGENCY BALLAST



ASSEMBLY AND INSTALLATION INSTRUCTIONS

WARNING: When using this lighting device, safety precautions should be followed at all times.

READ THE INSTRUCTIONS BELOW CAREFULLY AND FOLLOW THEM FOR YOUR OWN SAFETY.

1. Prior to installation, battery connector must be open to prevent high voltage from being present on output leads (red and yellow). It must be connected only after installation is complete and AC Power is supplied to the unit.
2. This unit can operate commonly used linear and compact fluorescent lamps. Please refer to the Lamp Compatibility Chart below for specific lamp information.
3. The 6" violet leads provide the lamp selection option. The unit is shipped from the factory with the leads disconnected and capped. When used with particular CFL / Long CFL lamp types, violet leads should be connected together. Refer to the Table 1 on the third page for lamp selection options. For non-CFLs / Long CFLs, the violet leads should remain disconnected.
4. Please ensure the electricity connections conform to the National Electrical Code and local regulations if applicable.
5. To avoid electric shock, please disconnect normal and emergency power supplies, and battery connector of the emergency ballast before servicing.
6. This device is designed for factory or field installation in either the ballast channel, or on top of the fixture, except air handling heated air outlets, sealed and gasketed fixtures, wet or hazardous location fixtures. Do not install this device near gas or electric heaters.
7. AC power source of 120 VAC or 277 VAC is required.
8. The battery is sealed, no-maintenance, and is not replaceable in the field. Please contact manufacturer for information on service. Do not attempt to service the battery.
9. Do not use accessory equipment that is not recommended by manufacturer. Failure to do so may cause unsafe conditions. Servicing should only be performed by qualified service personnel.
10. Do not use the product for other than its intended purpose.

SAVE THESE INSTRUCTIONS

LAMP COMPATIBILITY

- Compatible with most one-, two-, three-, and four-lamp electronic, standard and dimming AC ballasts.
- Operates the following lamps under emergency power:

	T5 (W)		T5HO (W)	T8 (W)	T12 (W)	4-Pin CFL (W)		4-Pin Long CFL (W)		T9 Circline (W)	U-Bend (W)	
	1	2	1	1	1	1	2	1	2	1	T8	T12
No. of Lamps	1	2	1	1	1	1	2	1	2	1	1	1
Wattage	14-28	14	39	25-40	40	13-42	13-18	18-40	18	32-40	32	34

KT-EMRG-750-CFL4 /B

CAUTION: Before installing, make certain the AC power is off and the emergency ballast's unit connector is disconnected.

1. MOUNTING THE EMERGENCY BALLAST(BATTERY PACK)

When used with ceiling mounted downlight fixtures, the emergency ballast should be mounted on the fixture above the ceiling. The flex conduit marked "A" should be wired into the ballast/lamp compartment or to an electrical junction box on the fixture which allows access to the ballast/lamp connection. Refer to Illustration 1 for typical mounting.

Note: The maximum mounting height for this model is 8 feet.

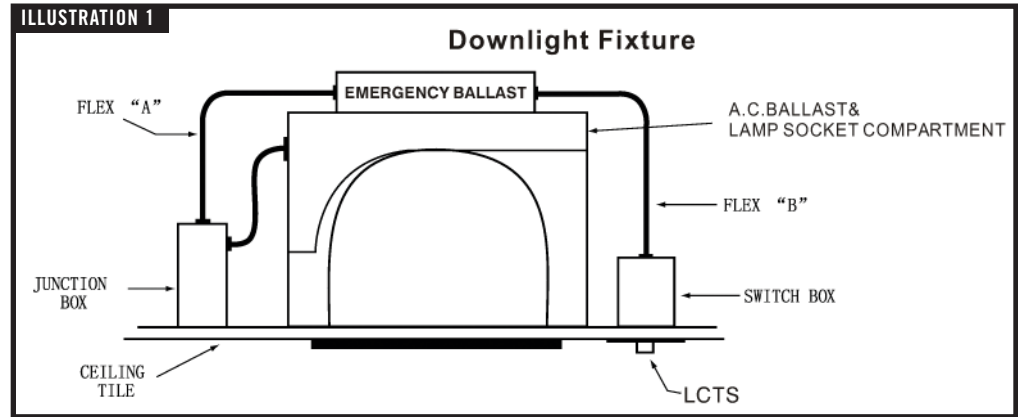

When battery packs are remote mounted, the remote distance cannot exceed 1/2 of the distance from ballast to lamp(s) specified by the AC ballast manufacturer. Under no circumstances should the battery pack exceed a distance 10' from the lamp.

2. INSTALLING THE LED COMBO TEST SWITCH (LCTS)

Cut the single gang switch box into the ceiling tile adjacent to the fixture within reach of the emergency ballast flex marked "B". After mounting the switch box, connect flex "B" to the box and route all leads inside the box. Refer to Illustration 1 for typical mounting.

3. WIRING

- A. The emergency ballast and AC Ballast must be on the same branch circuit.
- B. This emergency ballast requires an unswitched AC Power source of either 120 or 277 volts; therefore, when used with switched fixtures, input to the emergency ballast must be wired ahead of the switch. Refer to Illustration 2 for switched and unswitched fixture wiring diagrams.
- C. Refer to the wiring diagrams on the last page for proper wiring. For wiring diagrams of ballasts not shown, consult our customer service.

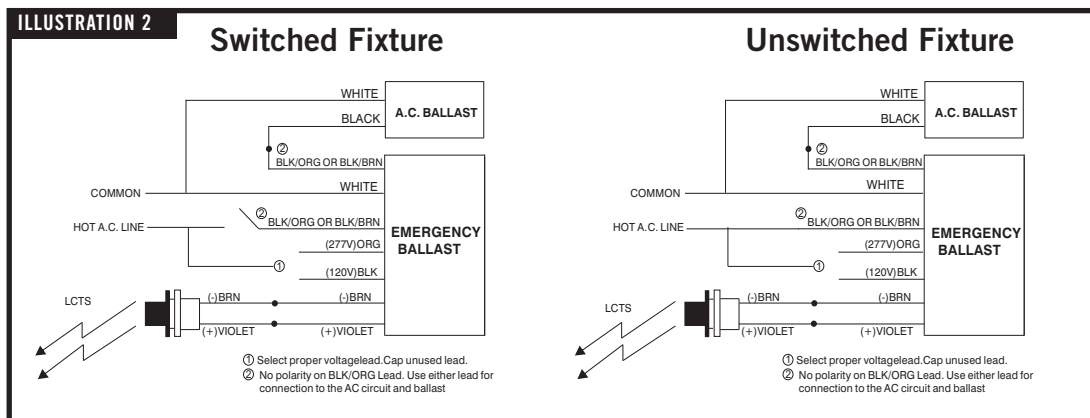

4. LABELS

Attach the appropriate labels adjacent to the LCTS. Annotate re-lamping label for lamp type and wattage. The 'Caution' and 'Re-lamping' labels must be on the fixture in a readily visible location to anyone attempting to service the fixture.

INSURE WIRING IS IN ACCORDANCE WITH NATIONAL ELECTRICAL CODE AND LOCAL REGULATIONS.

5. COMPLETING INSTALLATION

When the installation is complete, switch the AC power on and join the emergency ballast's unit connector.

KT-EMRG-750-CFL4 /B

OPERATION

General - This unit is primarily designed to be used with compact fluorescent lamp downlight fixtures. It will wire in conjunction with the existing AC ballast(s) and lamp(s) to provide the emergency function. It can also be wired for emergency only operation.

Normal Mode - AC power is present. The AC ballast operates the fluorescent lamp(s) as intended. The LCTS will be lit, providing a visual indication that the emergency ballast is in the standby charging mode.

Emergency Mode - The AC power fails. The emergency ballast senses the AC power failure and automatically switches to the emergency mode. One or two lamps illuminate, at reduced output, for a minimum of 90 minutes. When the AC power is restored, the emergency ballast switches the system back to the normal mode and resumes battery charging.

TESTING AND MAINTENANCE

Pressing the red lens on the LCTS turns off the light on the LCTS and forces the unit into emergency mode. This interrupts power to the emergency lamps only. The emergency lamp is now being lit by the emergency ballast unit and will be less bright than the other lamps in the system. To simulate a blackout, use the circuit breaker to turn off AC power.

Initial Testing - Allow the unit to charge for approximately 1 hour, then press the LCTS to conduct a short discharge test. Allow a 24 hour charge before conducting a 90 minute test.

This emergency ballast is a maintenance free unit. However, periodic inspection and testing is required. NFPA 101, Life Safety Code, outlines the following schedule:

Monthly - Insure that the LCTS is illuminated. Conduct a 30 second discharge test by depressing the LCTS. One or two lamps should operate at reduced output.

Annually - Insure that the LCTS is illuminated. Conduct a full 90 minute discharge test. The unit should operate as intended for the duration of the test.

SPECIAL INSTRUCTIONS

Refer to the chart below for the type of lamp(s) operated and the number of lamps to be operated in the emergency mode. If you have any questions regarding specific lamps, Contact Customer Service.

TABLE 1:

LAMP DIAMETER	BASE TYPE	WATTAGE (LENGTH)	NO. OF LAMPS (EMERGENCY MODE)	VIOLET CONNECTOR
COMPACT	G24q-1(4pin)	13W	1/2	CONNECTED
COMPACT	G24q-2(4pin)	18W	1	CONNECTED
COMPACT	G24q-2(4pin)	18W	2	DISCONNECTED
COMPACT	G24q-3(4pin) G24q-4(4pin)	26,42W	1	CONNECTED
LONG COMPACT	2G11(4pin)	18W	1	CONNECTED
LONG COMPACT	2G11(4pin)	18W	2	DISCONNECTED
LONG COMPACT	2G11(4pin)	36,40W	1	DISCONNECTED

Note: For non-CFLs / Long CFLs, the violet leads should remain disconnected.

“Written records of testing shall be kept by the owner for inspection by the authority having jurisdiction.”

SERVICING SHOULD BE PERFORMED BY QUALIFIED PERSONNEL.

WIRING DIAGRAMS

Typical wiring diagrams. For wiring diagrams of ballasts not shown, consult our customer service.

1. ONE LAMP RAPID START BALLAST

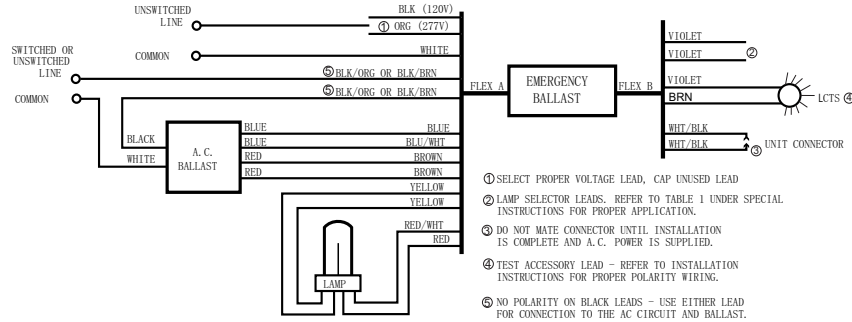

2. TWO LAMP RAPID START BALLAST WITH ONE LAMP EMERGENCY OPERATION

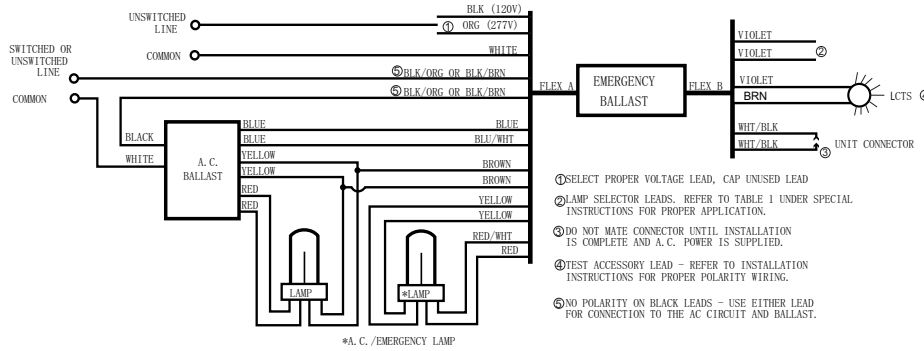

3. TWO LAMP RAPID START BALLAST WITH TWO LAMP EMERGENCY OPERATION

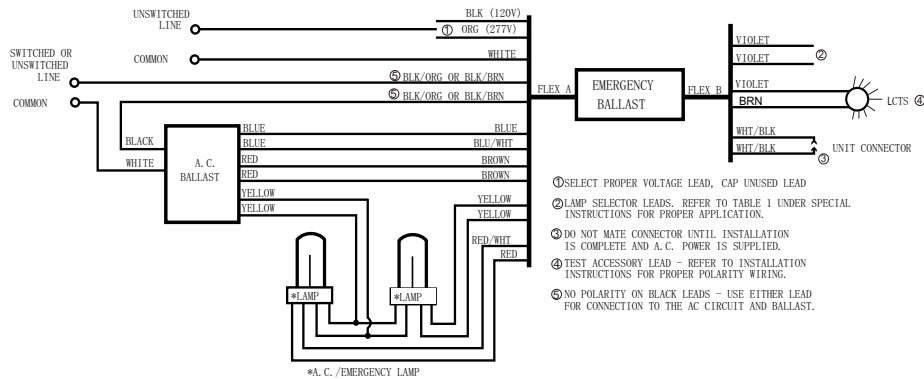

4. ALTERNATE TWO LAMP RAPID START BALLAST WITH ONE LAMP EMERGENCY OPERATION

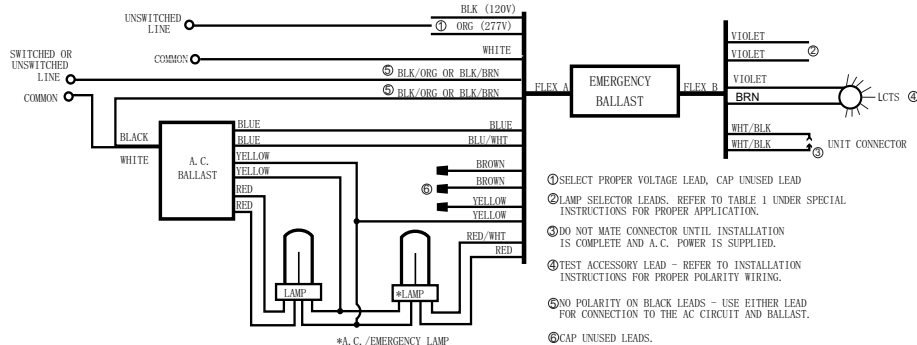

WIRING DIAGRAMS