

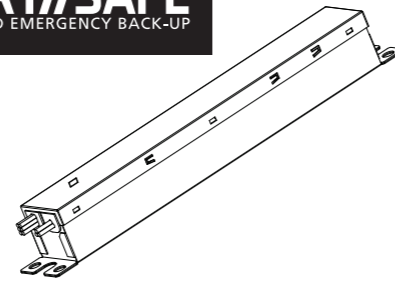

**SMART//SAFE**  
LED EMERGENCY BACK-UP



**KT-EMRG-LED-12-1200-AC /DF**

**Installation Instructions**

EMERGENCY LIGHTING EQUIPMENT

**IMPORTANT SAFEGUARDS**

When using electrical equipment, basic safety precautions should always be followed including the following:

**READ AND FOLLOW ALL SAFETY INSTRUCTIONS**

1. This is a sealed unit. Components are not replaceable. Replace the entire LED Emergency Backup unit when necessary.
2. Do not use outdoors.
3. This LED Emergency Backup unit requires an un-switched AC power source of 120-277V, 50/60 Hz, open circuit voltage: 200VDC. The AC driver MUST be on the same branch circuit as the LED Emergency Backup unit.
4. For use with most 14W through 40W T5, T8 or T12 single end or double end Type B LED lamps. It can provide a constant power output of about 10 watts in emergency mode. Operates one lamp in the emergency mode for a minimum of 90 minutes.
5. The Driver is intended for ordinary locations and for permanent installation into one or more Listed emergency luminaires.
6. Do not let power supply cords touch hot surfaces.
7. Do not mount near gas or electric heaters.
8. Install in accordance with the National Electrical Code and local regulations.
9. Equipment should be mounted in locations and at heights where it will not readily be subjected to tampering by unauthorized personnel.
10. The use of accessory equipment not recommended by the manufacturer may cause an unsafe condition.
11. Do not use this equipment for other than intended use.
12. Use with grounded, UL Listed, damp location rated fixtures and case should be grounding.
13. New batteries may require initial 12 hours charge before testing emergency function.
14. The emergency driver needs to be replaced if the battery discharged with environment temperature below 0°C(32°F).
15. Max. mounting height:

Model	Luminaire	Max. mounting height
KT-EMRG-LED-12-1200-AC /DF	One (1) LED tube, Classified (IFAR/7) KEYSTONE TECHNOLOGIES (E472082), Model KT-EMRG-LED-12-1200-AC /DF with 3000~5000K color temperature and opal diffuser, LEDs manufactured by bridgelux, Inc, model 2835.	17.26 ft (5.26 m)

\* Other luminaire Max. mounting height can be found as follow:

1. Log onto the DesignLights Consortium website ([www.designlights.org](http://www.designlights.org)).
2. Click on "search the DLC Qualified Product List" button on the DLC homepage.
3. In the "search by keyword" text window enter: luminaire manufacturer name and part number.
4. Click on "Search" tab to open the "Qualified Products List."
5. Determine per "Reported Date" efficacy shown in lumens per watt-(lm/w). Multiply lumens per watt by KT-LEDxxT8-XXxx-Xxx-xxx rated output(example: lm/w x 10watts). Refer to table below for the wattage of the specific KT-LEDxxT8-XXxx-Xxx-xxx model to be used in the luminaries. (lm/w) x KT-LEDxxT8-XXxx-Xxx-xxx =Minimum emergency lumens of fixture.

Model	Output Power(Constant)
KT-EMRG-LED-12-1200-AC /DF	10 Watts

6. Follow industry standards by utilizing available.ies files and lighting design software for your dedicated emergency luminaires, with the above calculated emergency lumens, and validate your as-installed plans in accordance with the applicable life safety codes governing your project.

While these products are compliant with the requirements of UL Standard 924, it is ultimately the responsibility of the designer/specifier to assure the as-installed system delivers code compliant path of egress illumination in accordance with federal, state or local municipal requirements.

**SAVE THESE INSTRUCTIONS**

Keystone Technologies • Philadelphia, PA • Phone (800) 464-2680 • [www.keystonetech.com](http://www.keystonetech.com)  
Specifications subject to change. Last revised on 10.29.21

**INSTALLATION**

**WARNING:** TO PREVENT HIGH VOLTAGE FROM BEING PRESENT ON RED & BLUE OUTPUT LEADS PRIOR TO INSTALLATION, BATTERY CONNECTOR MUST BE OPEN. DO NOT JOIN BATTERY CONNECTOR UNTIL INSTALLATION IS COMPLETE AND AC POWER IS SUPPLIED TO THE EMERGENCY DRIVER.

**INSTALLING THE EMERGENCY DRIVER**

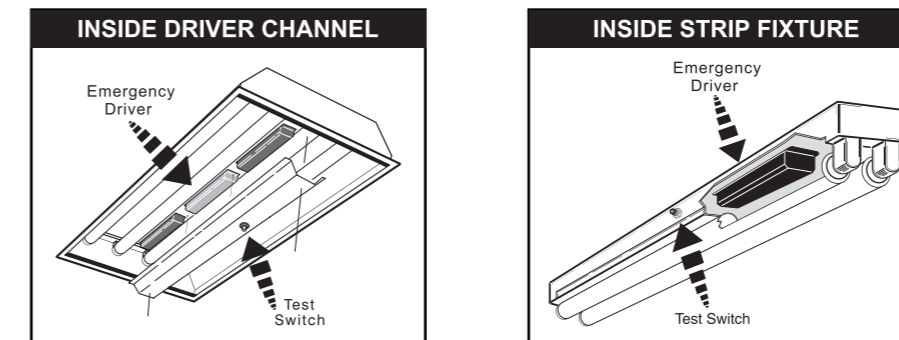

**INSTALLING THE TEST SWITCH**

Refer to the illustrations above and install the test switch through the driver channel cover of a troffer or through the side of a strip fixture.

Drill a 1/2" hole and install the switch as shown.

Wire the test switch so that it removes AC power from the unswitched hot line to the emergency driver.

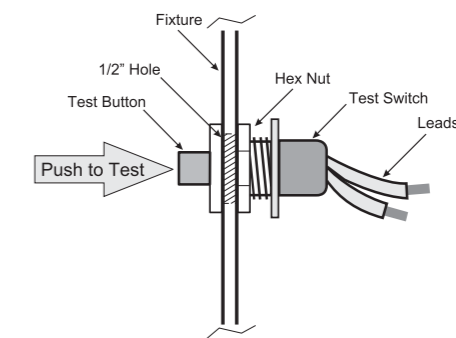

**INSTALLING THE CHARGING INDICATOR LIGHT**

Install the CHARGING INDICATOR LIGHT as shown in the illustration below so that it will be visible after the fixture is installed.

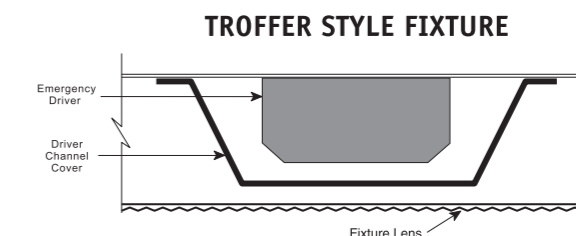

**Wiring Diagrams**

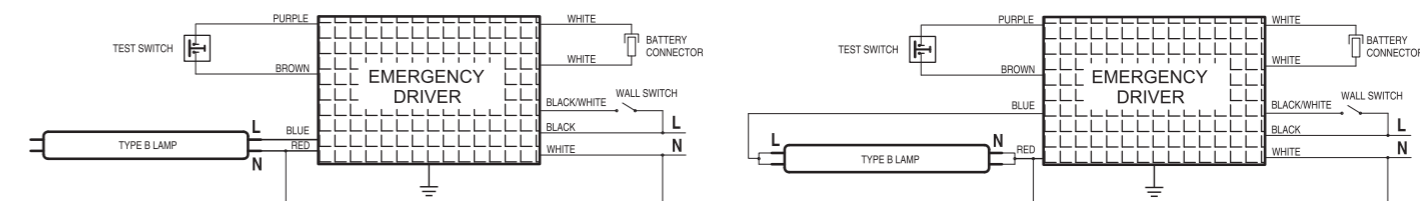

**Operation**

Normal Mode: AC power is present. The AC driver operates the LED load as designed. The emergency pack is charging in a standby mode. The test button will be lit, showing that the battery is charging.  
Emergency Mode: When the AC power goes out, the emergency pack detects the power outage and automatically switches to the emergency mode. The LED load is illuminated, for a minimum of 90 minutes. When AC power is restored, the emergency pack switches back to Normal Mode and starts re-charging.

**FCC Statement**

This device complies with Part 15 of the FCC Rules. Operation is subject to the following two conditions: (1) this device may not cause harmful interference, and (2) this device must accept any interference received, including interference that may cause undesired operation.

**MAINTENANCE**

Although no routine maintenance is required to keep the emergency driver functional, it should be checked periodically to ensure that it is working. The following schedule is recommended:

1. Visually inspect the charging indicator light monthly. It should be illuminated.
2. Test the emergency operation of the fixture at 30-day intervals for a minimum of 30 seconds. One lamp should operate at reduced illumination.
3. Conduct a 90-minute discharge test once a year. One lamp should operate at reduced illumination for at least 90 minutes.

290 mm

210 mm

ZMT-A10-200610