



MH-250A-Q-KIT 3/1

250W METAL HALIDE BALLAST KIT



DESCRIPTION

250W Metal Halide Ballast Kit | Quad Tap

LAMP TYPE: 250W Standard Metal Halide (M58 or H37)

INPUT VOLTAGE: Quad Tap (120/208/240/277)

CIRCUIT TYPE: CWA (without Ignitor)

WARRANTY: 2 Years



PRODUCT FEATURES

- ANSI Designation: M58 or H37
- Line Voltage: 120/208/240/277
- Regulation: 10%
- Frequency: 60 Hz
- Recommended Fuse (A): 8/5/4/3
- Circuit Type: CWA (Without Ignitor)
- Insulation Class: 180°C
- Capacitor Value: 15 μ F
- Capacitor Voltage Rating: 400 V
- Capacitor Temperature Rating: 90°C
- Winding Materials: Copper/Aluminum
- Lamp Starter: N/A
- Agency Certification: RU, cRU
- Maximum Distance to Lamp: N/A

ELECTRICAL SPECIFICATIONS

Line Voltage	Power Factor	Line Current			Input Power	Open Circuit Voltage	Minimum Start Temperature	UL Temp. Code
		Operating	Open	Start				
120V	High	2.40mA	2.19mA	1.81mA	285W	310V	-30°C/-22°F	A
208V	High	1.43mA	1.28mA	1.05mA	285W	310V	-30°C/-22°F	A
240V	High	1.22mA	1.11mA	0.91mA	285W	310V	-30°C/-22°F	B
277V	High	1.06mA	0.97mA	0.80mA	285W	310V	-30°C/-22°F	A

WIRING DIAGRAM

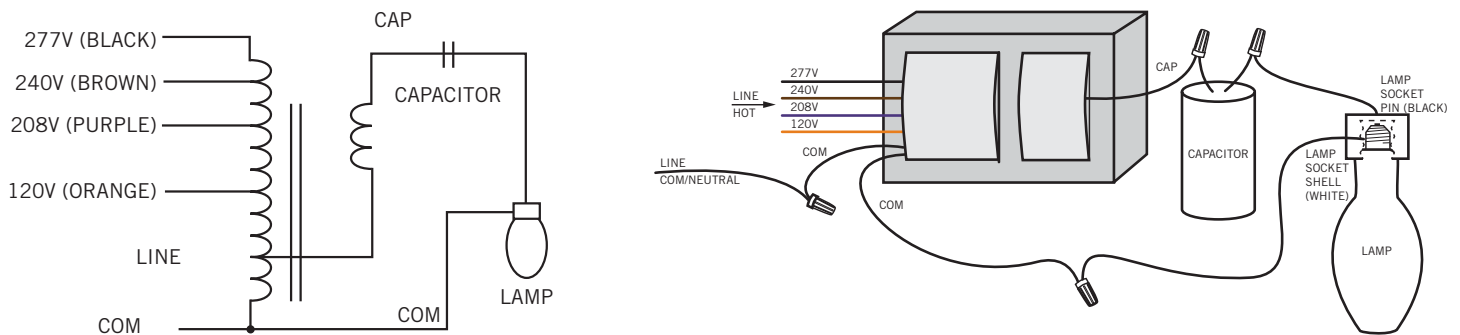



MH-250A-Q-KIT 3/1

250W METAL HALIDE BALLAST KIT

PHYSICAL SPECIFICATIONS

CASE STYLE

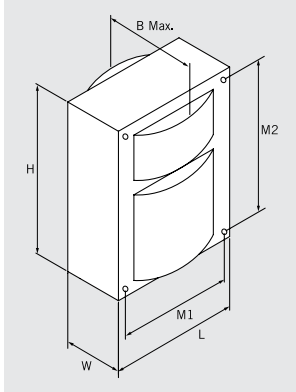

OVERALL DIMENSIONS			
LENGTH	WIDTH	HEIGHT	B MAX.
4.30"	1.65"	4.80"	3.50"

MOUNTING HOLES		
DIAMETER	M1	M2
0.25"	3.87"	4.37"

BRACKET DIMENSIONS		BALLAST NET WEIGHT	LEAD LENGTH
LENGTH	WIDTH		
7.25"	1.11"	8.05 lbs	12-14"

CAPACITOR SPECIFICATIONS

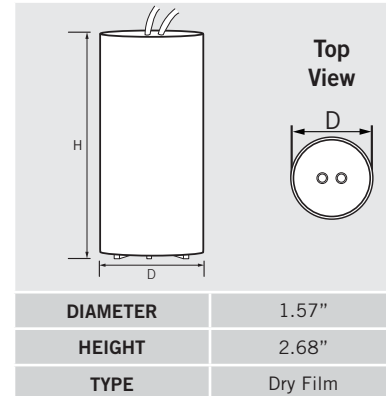

DIAMETER	1.57"
HEIGHT	2.68"
TYPE	Dry Film

ORDERING INFORMATION

Order Code	Packaging Style	Package Quantity	Item Status
MH-250A-Q-KIT 3/1	Kit	1	Quick Ship

Kit includes pre-wired ballast, capacitor, mounting brackets, and mounting hardware

CATALOG NUMBER BREAKDOWN

MH-250A-Q-KIT				
Metal Halide	Wattage	CWA Circuit	Quad Tap	Ballast Kit