



SMARTWIRE
ELECTRONIC SIGN BALLASTS

KTSB-E-2048-46-UV-S

DESCRIPTION

4-6 Lamps | T8HO or T12HO | 20'-48' Combined Lamp Length | Series Wiring



STARTING METHOD: Programmed Rapid Start

INPUT VOLTAGE: 120-277VAC ±10%

LAMP CONNECTION: Series

INPUT FREQUENCY: 60Hz

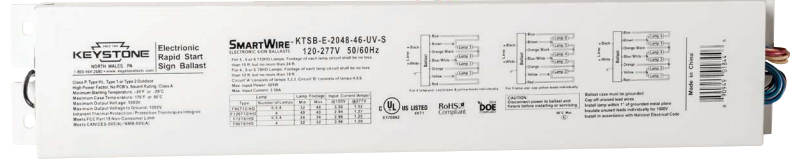

PRODUCT FEATURES

- Sound Rated: A
- Minimum Starting Temperature: -20°F, -29°C
- Maximum Case Temperature: 176°F, 80°C
- Meets FCC Part 18 (Class A) Non-Consumer Limits
- UL, cUL 935 Listed, Class P, Type 2 Outdoor, Type HL

ELECTRICAL SPECIFICATIONS

Lamps		Lamp Footage*		Input Voltage	Max Input Watts	Nominal Line Amps	Power Factor	Harmonic Total	Crest Factor
Type	Number of Lamps	Min.	Max.						
T12HO	6,5,4	20	48	120	435	3.65	> 0.90	< 10	< 1.7
		20	48	277	420	1.52	> 0.90	< 10	< 1.7
T8HO	6,5,4	20	36	120	390	3.25	> 0.90	< 10	< 1.7
		20	36	277	385	1.39	> 0.90	< 10	< 1.7

*Only for use with lamps up to 8'; for lamps greater than 8' use KTSB-E-1040-14-UV

LAMP FOOTAGE

Lamp Type	Minimum	Maximum
T12HO	20'	48'
T8HO	20'	36'

MECHANICAL SPECIFICATIONS

CASE DIMENSIONS

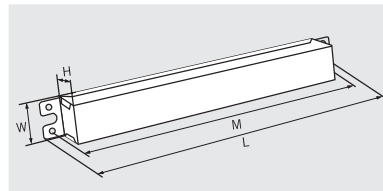

LENGTH	16.7"
WIDTH	3.15"
HEIGHT	1.18"
MOUNTING	15.95"
CASE STYLE	L31

STANDARD LEAD LENGTHS*

WHITE	25"
BLACK	25"
RED	72"
YELLOW	72"
BLUE	72"
ORANGE	72"
ORANGE/BLACK	72"
BROWN	72"
BLUE/WHITE	72"

Lead wires are 18 AWG 105°C/600V, solid copper.

CASE MATERIAL: Metal

*Consult Keystone for special lead length requirements.

FOR INSTALLATION PURPOSES

Ballast consists of two lamp circuits - Circuit A and Circuit B. Circuit A consists of lamps 1, 2, 3 and Circuit B consists of lamps 4, 5, 6.

- Using lamps up to 8' each lamp circuit can drive 2 or 3 T12HO lamps in any combination from 10'-24'
- Using lamps up to 8' each lamp circuit can drive 2 or 3 T8HO lamps in any combination from 12'-18'

Each lamp circuit should be balanced with equal lamp load (footage).

WIRING DIAGRAMS

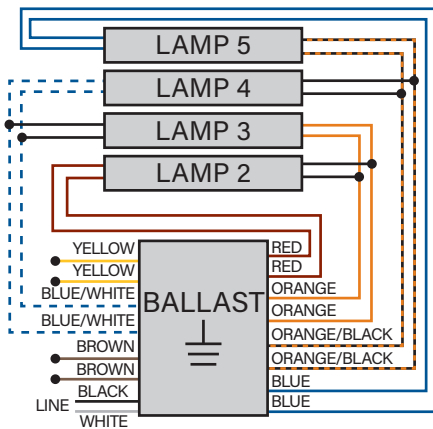

Four Lamp Application, Cap Off
Unused Leads Individually,
Insulate to 600V

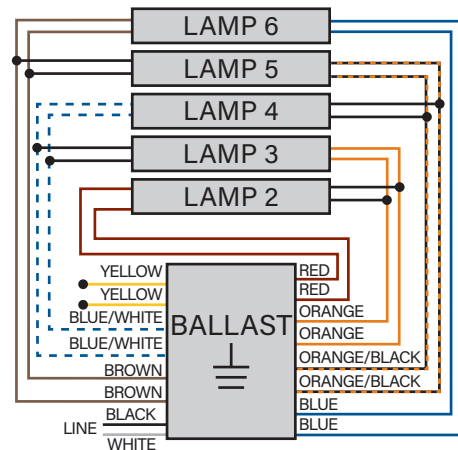

Five Lamp Application, Cap Off
Unused Leads Individually,
Insulate to 600V

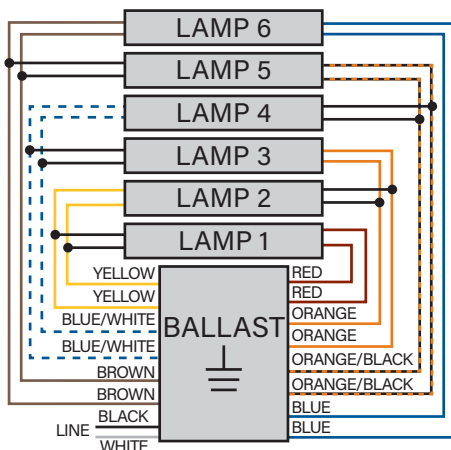

Six Lamp Application



SMARTWIRE
ELECTRONIC SIGN BALLASTS

KTSB-E-2048-46-UV-S

ORDERING INFORMATION

ORDER CODE	PACKAGING STYLE	PACK QTY.	ITEM STATUS
KTSB-E-2048-46-UV-S-IP	Individually Packaged	1	Quick Ship

CATALOG NUMBER BREAKDOWN

KT S B - E - 2 0 4 8 - 4 6 - U V - S - I P

1

2

3

4

5

6

7

8

9

1 Keystone Technologies Sign Ballast

2 Electronic

3 Minimum Total Lamp Length*

4 Maximum Total Lamp Length*

5 Minimum Number of Lamps

6 Maximum Number of Lamps

7 120-277V Input

8 SmartWire

8 Packaging Style

*Minimum and maximum total lamp length based on T12HO lamps.