



PRODUCT FEATURES

- ANSI Designation: M48
- Line Voltage: 120/208/240/277
- Regulation: 10%
- Frequency: 60 Hz
- Recommended Fuse (A): 40/25/20/20
- Circuit Type: CWA (Without Ignitor)
- Insulation Class: 180°C
- Capacitor Value: 32 MF
- Capacitor Voltage Rating: 525 V
- Capacitor Temperature Rating: 90°C
- Winding Materials: Cu/Cu
- Lamp Starter: N/A
- Agency Certification: RU, cRU
- Maximum Distance to Lamp: N/A
- 2 Year Warranty

LAMP TYPE: 1500W MH

INPUT VOLTAGE: Quad Tap (120/208/240/277)

CIRCUIT TYPE: CWA (Without Ignitor)

ELECTRICAL SPECIFICATIONS

LINE VOLT (V)	POWER FACTOR	LINE CURRENT			INPUT POWER (W)	OPEN CIRCUIT VOLTAGE (V)	MINIMUM START TEMP	UL TEMP CODE	WIRING DIAGRAM
		OPERATING	OPEN	START					
120	High	13.50	3.94	13.20	1610	453	-30°C	D	H2
208	High	7.80	2.15	7.76	1610	453	-30°C	D	H2
240	High	6.80	1.89	6.55	1610	453	-30°C	E	H2
277	High	5.90	1.71	5.73	1610	453	-30°C	E	H2

WIRING DIAGRAMS

DIAGRAM H2

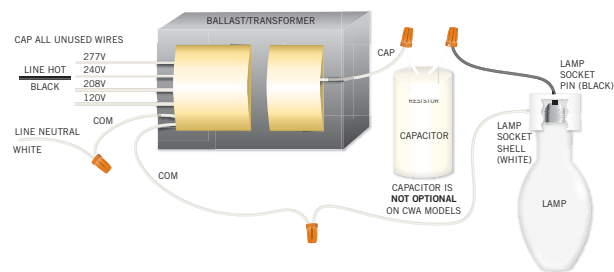
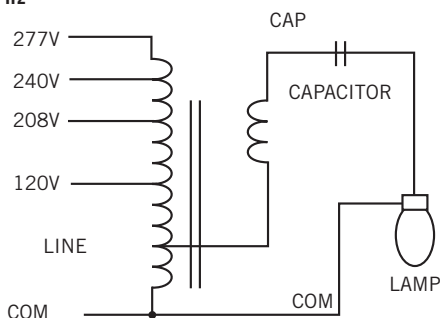

CAP ALL UNUSED WIRES
 LINE HOT 277V
 BLACK 240V
 208V
 120V
 LINE NEUTRAL WHITE
 COM
 COM
 CAP
 RESISTOR
 CAPACITOR
 CAPACITOR IS NOT OPTIONAL ON CWA MODELS
 LAMP SOCKET PIN (BLACK)
 LAMP SOCKET SHELL (WHITE)
 LAMP

CASE STYLE/DIMENSIONS

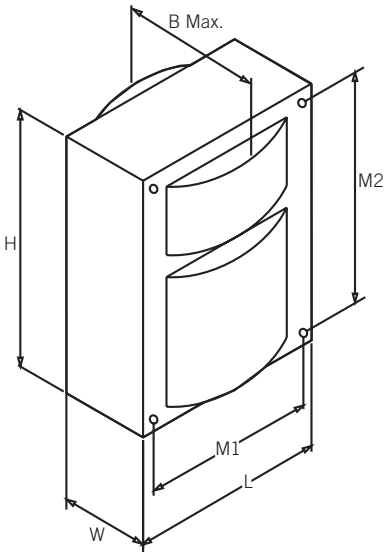

OVERALL DIMENSIONS

LENGTH: 4.25"
WIDTH: 4.13"
HEIGHT: 6.00"
B MAX: 6.69"

MOUNTING HOLES

DIAMETER: 0.25"
M1: 3.87"
M2: 5.37"

BRACKET DIMENSIONS

LENGTH: 7.25"
WIDTH: 1.11"

LEAD LENGTH: 12-14"

BALLAST NET WEIGHT: 29.54lbs

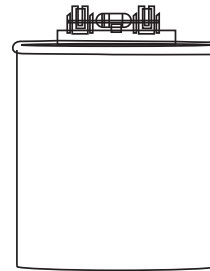

CAPACITOR INFO

WATTAGE: 1500
MICROFARAD: 32
VOLTAGE: 525 V
TYPE: Oil Filled

ORDERING INFORMATION

ORDER CODE	PACKAGING STYLE	PACK QTY.	ITEM STATUS
MH-1500A-Q-KIT		1	Quick Ship
*Kit Includes: Pre-Wired Ballast, Capacitor, Mounting Brackets, Mounting Hardware			

CATALOG NUMBER BREAKDOWN

MH-1500A-Q-KIT

