



KT-LED162P-V-8XX-D

2-PIN LED CFL REPLACEMENT LAMP

DESCRIPTION

16W 2-Pin LED Lamp | 2700-5000K | G24d Base | Type B Line Voltage Compatible



LAMP TYPE: 2-PIN LED CFL Replacement
BULB TYPE: 2-Pin LED
BASE TYPE: G24d
WATTAGE: 16W
COLOR TEMPERATURE: 2700-5000K
COLOR RENDERING INDEX (CRI): ≥80
WARRANTY: 5 Years



PRODUCT FEATURES

- Replaces 42W legacy lamps with G24q, GX24q, G24d, and GX24d bases
- G24d 2-pin bases can be used in G24Q 4-pin applications for ballast bypass
- Approximately 50% more energy efficient vs legacy CFL lamps
- Up to 5x longer life vs traditional lamps
- Frosted diffuser that eliminates pixilation and glare
- Environmentally friendly. No mercury used
- Instant startup
- UL Classified Retrofit Kit
- Non dimmable
- 50,000 hour lifetime
- Operating temperature: -20°C/-4°F to 40°C/104°F
- Not for use in full enclosed luminaires
- Minimum compartment dimensions: 20cm x 15cm / 7.87" x 5.91"

PERFORMANCE SPECIFICATIONS

Catalog Number	Wattage	CCT	Lumens	Efficacy	Input Voltage	CRI	Base Type	Beam Angle	Related Life
KT-LED162P-V-827-D	16W	2700K	1700	106 lm/W	120-277V	> 80	G24d	> 110°	50,000 hrs
KT-LED162P-V-830-D		3000K	1750	109 lm/W					
KT-LED162P-V-835-D		3500K	1800	113 lm/W					
KT-LED162P-V-840-D		4000K	1850	116 lm/W					
KT-LED162P-V-850-D		5000K	1900	119 lm/W					



KT-LED162P-V-8XX-D

2-PIN LED CFL REPLACEMENT LAMP

PHOTOMETRIC SPECIFICATIONS

POLAR CANDELA DISTRIBUTION

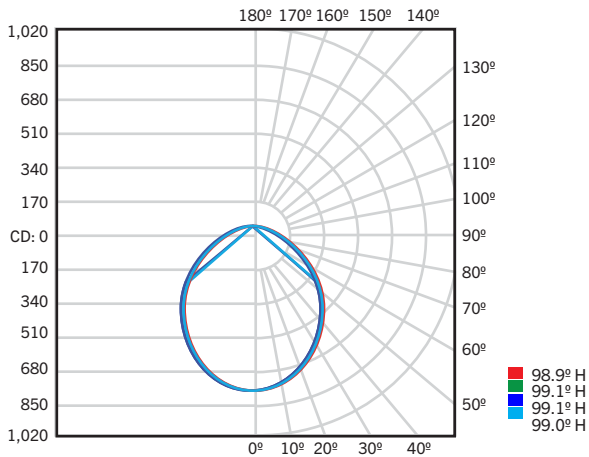

SPECTRAL DISTRIBUTION

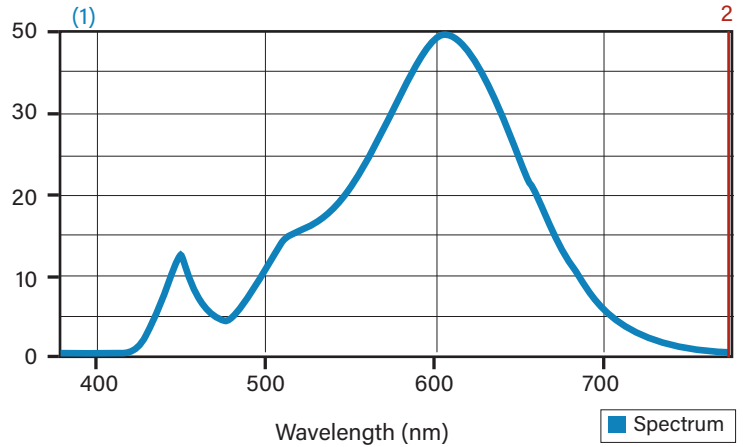

WIRING DIAGRAMS

BYPASS MAGNETIC BALLAST WITH 1 LAMP

BEFORE

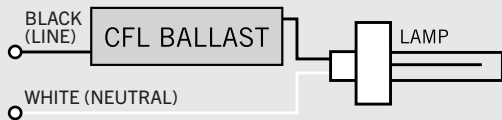

AFTER

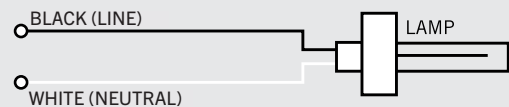

BYPASS ELECTRONIC BALLAST WITH 1 LAMP

BEFORE

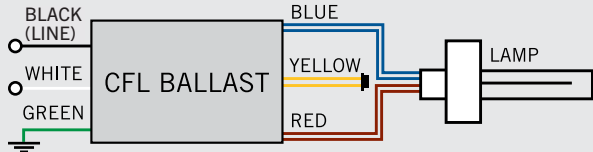

AFTER

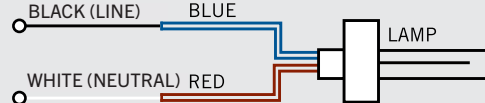

BYPASS MAGNETIC BALLAST WITH 2 LAMPS

BEFORE

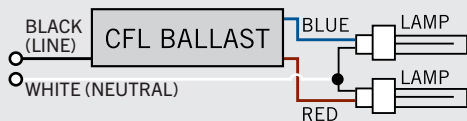

AFTER

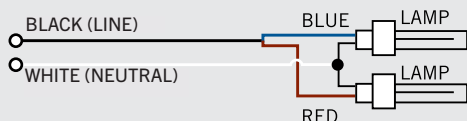

BYPASS ELECTRONIC BALLAST WITH 2 LAMPS

BEFORE

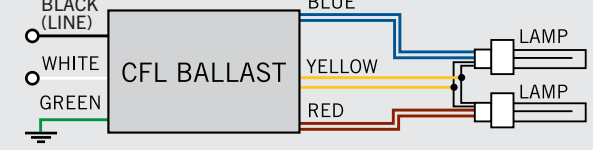

AFTER

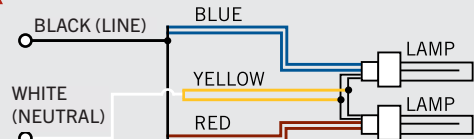



KT-LED162P-V-8XX-D

2-PIN LED CFL REPLACEMENT LAMP

PHYSICAL SPECIFICATIONS

LAMP DIMENSIONS

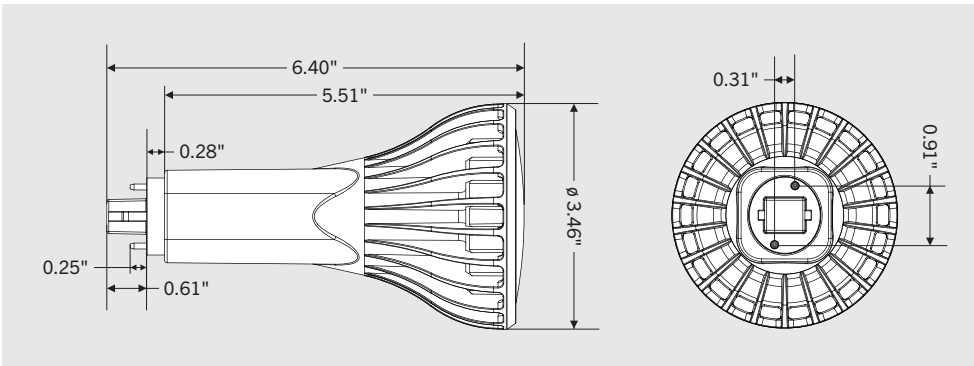

ORDERING INFORMATION

CATALOG NUMBER	EASY CODE	UPC
KT-LED162P-V-827-D-DP	YNF-80	843654127668
KT-LED162P-V-830-D-DP	RMU-71	843654127675
KT-LED162P-V-835-D-DP	ORV-07	843654127682
KT-LED162P-V-840-D-DP	ZUL-50	843654127699
KT-LED162P-V-850-D-DP	JZY-85	843654127705

CATALOG NUMBER BREAKDOWN

KT-LED162P-V-8XX-D

- 1
- 2
- 3
- 4
- 5
- 6
- 7
- 8

- 1 Keystone Technologies
- 2 LED Lamp
- 3 Wattage
- 4 Lamp Type
- 5 Orientation
- 6 80 CRI
- 7 CCT
- 8 Combo Drive Series