



# KTLD-60-UV-12V-MC1

## CONSTANT VOLTAGE LED DRIVER

Class 2



SAM



FC

RoHS Compliant



5 YEAR WARRANTY

### DESCRIPTION

LED Driver | 60W | 120/277V Input | 12V Output

<b>TOTAL POWER:</b> 60W
<b>INPUT VOLTAGE:</b> 120/277Vac $\pm$ 10%
<b>INPUT FREQUENCY:</b> 50/60 Hz
<b>OUTPUT VOLTAGE:</b> 12V
<b>DIMMING:</b> Fixed Output
<b>WARRANTY:</b> 5 Years
<b>LOCATION:</b> Suitable for dry and damp locations



### ELECTRICAL SPECIFICATIONS

<b>Input Voltage Range</b>	120/277Vac $\pm$ 10%
<b>Frequency</b>	50/60 Hz
<b>Power Factor</b>	> 0.9 under 120/277Vac input with 80~100% load condition
<b>Max. Input Current</b>	0.7A @120V, 0.4A @230V and 0.3A @277V
<b>THD</b>	$\leq$ 20% under 120/277Vac input with 80~100% load condition
<b>Output Tolerance</b>	$\pm$ 5% at Full Load Condition
<b>Turn-On Delay Time</b>	$\leq$ 0.5s at Full Load Condition
<b>Overshoot</b>	< 10% at Full Load Condition
<b>Ripple &amp; Noise (pk-pk)</b>	$\leq$ 5% of rated output voltage for each model
<b>Leakage Current</b>	400 $\mu$ A @120V, 800 $\mu$ A @230V, 920 $\mu$ A @ 277V
<b>Protection</b>	<ul style="list-style-type: none"> <li>Under-Voltage (Brownout): Provides protection circuitry such that an application of an input voltage below the minimum stated in section 1 (Input Specification) shall not cause damage to the driver.</li> <li>Short Circuit and Over Current Protection: Protected against short-circuit such that a short from any output to return shall not result in a fire hazard or shock hazard. The driver shall hiccup as a result of a short circuit or over current fault. Removal of the fault will return the driver to within normal operation. The driver shall recover, with no damage, from a short across the output for an indefinite period of time.</li> <li>Internal Over temperature Protection: Equipped with an internal temperature sensor on the primary power train. Failure to stay within the convection power rating will cause the driver to shut down. The main output current will be resumed when the temperature of the built-in temperature sensor cools adequately.</li> <li>Output Open Load : A no load condition will not damage the driver or cause a hazardous condition. The driver will remain stable and operate normally after application of a load. When the LED load is removed, the output voltage of the driver is limited to about 7% of the output voltage of each model.</li> <li>Over Power Protection: Will shut down and auto recover when its input power exceeds approximately 110% of 96 W. This condition will cause no damage to the power supply.</li> <li>Input Over Current Protection: Incorporates a primary AC line fuse for input over current protection.</li> </ul>

### ENVIRONMENTAL SPECIFICATIONS

<b>Operating Temperature</b>	-20 to 50°C
<b>Storage Temperature</b>	-40 to 85°C
<b>Humidity</b>	5% to 95%
<b>MTBF</b>	> 200,000 hours when operated at nominal input and output conditions, and at Tc $\leq$ 70°C
<b>Life Rating</b>	50,000 hours at Tc $\leq$ 70°C maximum case hot spot temperature
<b>Maximum Case Temperature</b>	90°C

### SAFETY AND EMC COMPLIANCE

<b>UL/cUL</b>	UL 8750, Class P, Class 2
<b>FCC, 47CFR Part 15</b>	Meets Class B @ 120V and Class A @ 277V



# KTLD-60-UV-12V-MC1

## CONSTANT VOLTAGE LED DRIVER

### PRODUCT SPECIFICATIONS

Catalog Number	Max. Output Power	Output Current	Output Voltage	OCV	Typical Efficiency at 120V	Typical Efficiency at 240V	Typical Efficiency at 277V	Class 2	
								US	Canada
KTLD-60-UV-12V-MC1	60W	5A	12V	12.8V	89%	91%	91%	✓	✓

### PHYSICAL SPECIFICATIONS

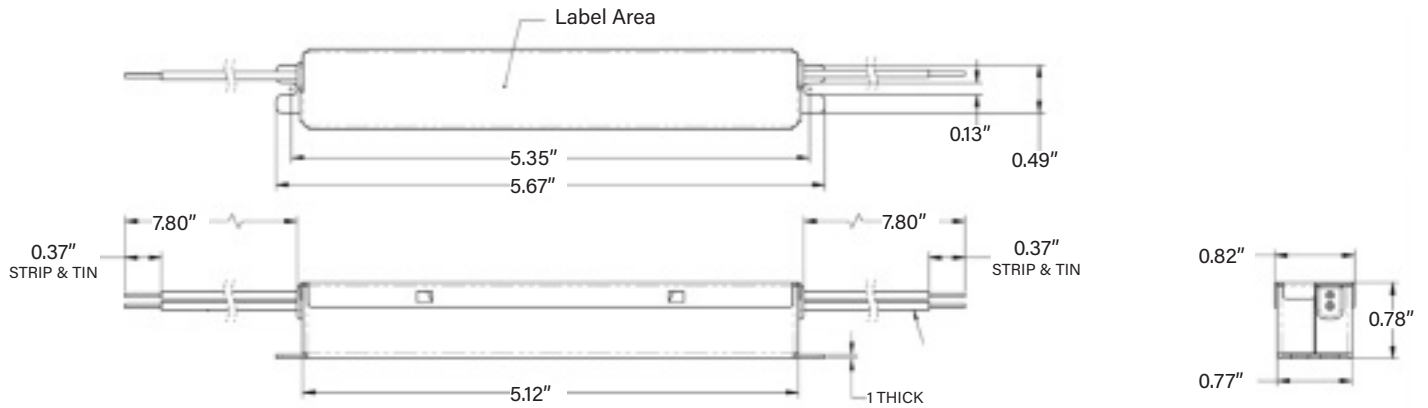

### WIRING DIAGRAM

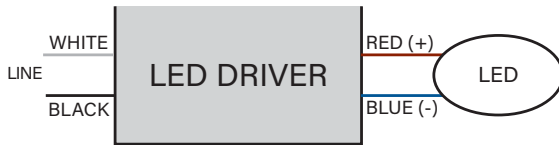

### WIRING SPECIFICATIONS

<b>INPUT</b>	203mm, Stranded and Tinned 9.5mm, 18AWG, 105°C, 300V
<b>OUTPUT</b>	203mm, Stranded and Tinned 9.5mm, 18AWG, 105°C, 300V

### ORDERING INFORMATION

ORDER CODE	PACKAGING STYLE	PACK QTY.	ITEM STATUS
KTLD-60-UV-12V-MC1-CP	Carton Pack	100 ea.	Quick Ship

### CATALOG NUMBER BREAKDOWN

# KTLD-60-UV-12V-MC1-CP

1

2

3

4

5

6

- 1 Keystone Technologies LED Driver
- 2 Max. Output Wattage
- 3 120-277V Input
- 4 Output Voltage
- 5 Case Style
- 6 Packaging Style