

INSTALLATION AND OPERATING INSTRUCTIONS

CAT. NO. KT-HBLED-EM-BR-KIT

ADDITIONAL ACCESSORIES

Emergency Battery Backup

STEP 1: Install the emergency battery backup mounting bracket on the drive box with bolts (see Figure 1A).

STEP 2: Screw the hook brackets on the end caps, then mounting V-hooks (see Figure 2A).

STEP 3: Connect the wires to the AC power grounding leads. Make sure the wires are enclosed in the flexible metallic conduit.

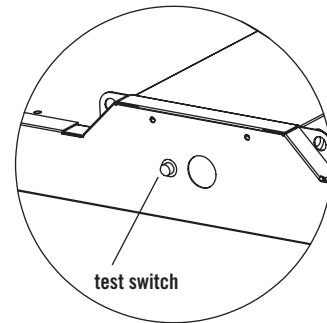
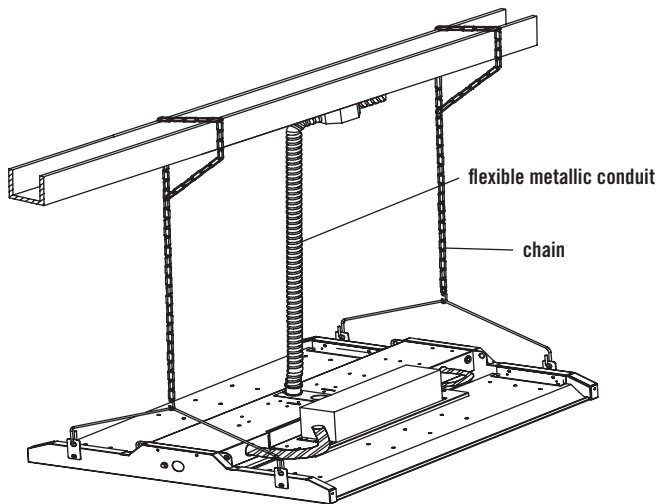

FIGURE 1

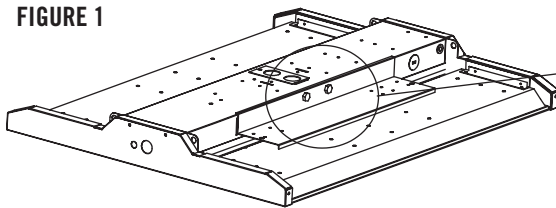

FIGURE 1A

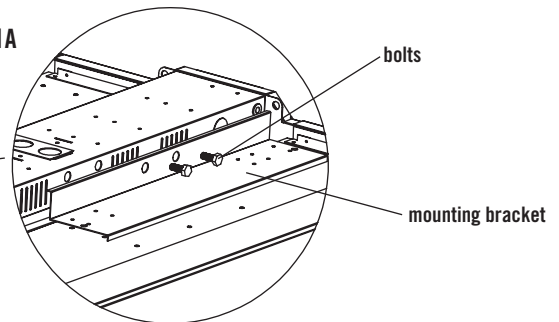

FIGURE 2

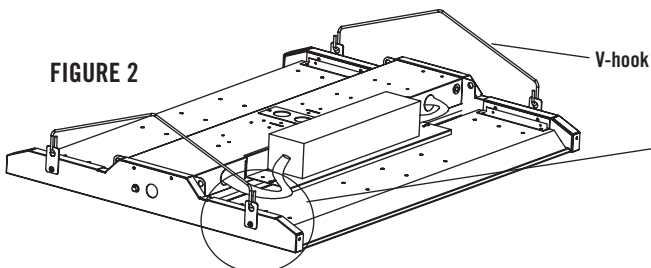

FIGURE 2A

