



KT-LED82P-V-8XX-D / G2

2-PIN LED CFL REPLACEMENT LAMP

DESCRIPTION

8W 2-Pin LED Lamp | 3500K - 5000K | G24d Base |
Type B Line Voltage Compatible



LAMP TYPE: LED CFL Replacement
BULB TYPE: 2-Pin LED
BASE TYPE: G24d
WATTAGE: 8W
COLOR TEMPERATURE: 3500K - 5000K
COLOR RENDERING INDEX (CRI): > 80
WARRANTY: 5 Years



PRODUCT FEATURES

- Replaces 13W, 18W, and 26W legacy lamps with G24q, GX24q, G24d, and GX24d bases
- G24d 2-pin bases can be used in G24Q 4-pin applications for ballast bypass
- Approximately 50% more energy efficient vs legacy CFL lamps
- Up to 5x longer life vs traditional lamps
- Frosted diffuser that eliminates pixilation and glare
- Environmentally friendly. No mercury used
- Instant startup
- UL Classified Retrofit Kit
- Suitable for use in damp locations
- Not for use in enclosed luminaires
- Non dimmable
- 50,000 hour lifetime
- Operating temperature: -20°C/-4°F to 45°C/113°F
- Compliant with FCC Part 15 Class B
- Minimum compartment dimensions: 6.31" D x 9.06" H

*G24q-5/6/7 and Gx24q-5/6/7 not compatible

PERFORMANCE SPECIFICATIONS

Catalog Number	Wattage	CCT	Lumens	Efficacy	Input Voltage	CRI	Base Type	Beam Angle	Related Life
KT-LED82P-V-835-D /G2	8W	3500K	1000	125 lm/W	120-277V	> 80	G24d	> 110°	50,000 hrs
KT-LED82P-V-840-D /G2		4000K	1050	131 lm/W					
KT-LED82P-V-850-D /G2		5000K	1050	131 lm/W					

KT-LED82P-V-8XX-D / G2
2-PIN LED CFL REPLACEMENT LAMP

WIRING DIAGRAM

BYPASS MAGNETIC BALLAST WITH 1 LAMP

BEFORE

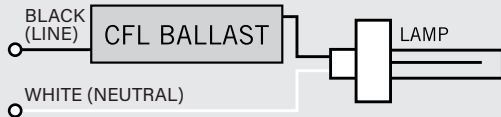

AFTER

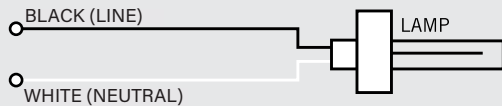

BYPASS ELECTRONIC BALLAST WITH 1 LAMP

BEFORE

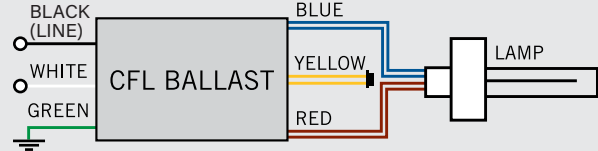

AFTER

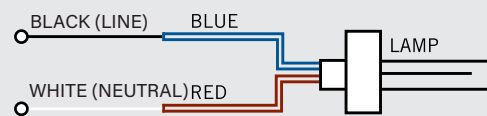

BYPASS MAGNETIC BALLAST WITH 2 LAMPS

BEFORE

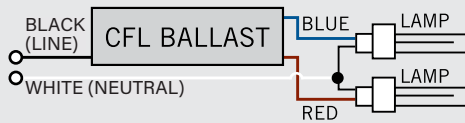

AFTER

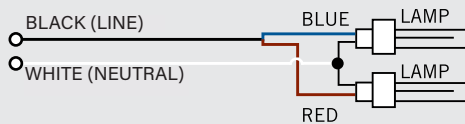

BYPASS ELECTRONIC BALLAST WITH 2 LAMPS

BEFORE

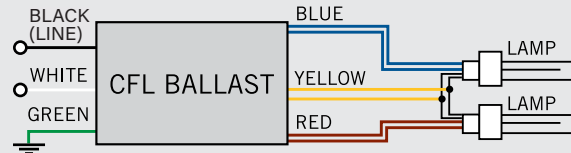

AFTER

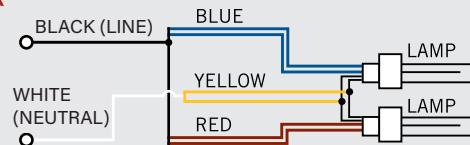



KT-LED82P-V-8XX-D / G2

2-PIN LED CFL REPLACEMENT LAMP

PHYSICAL SPECIFICATIONS

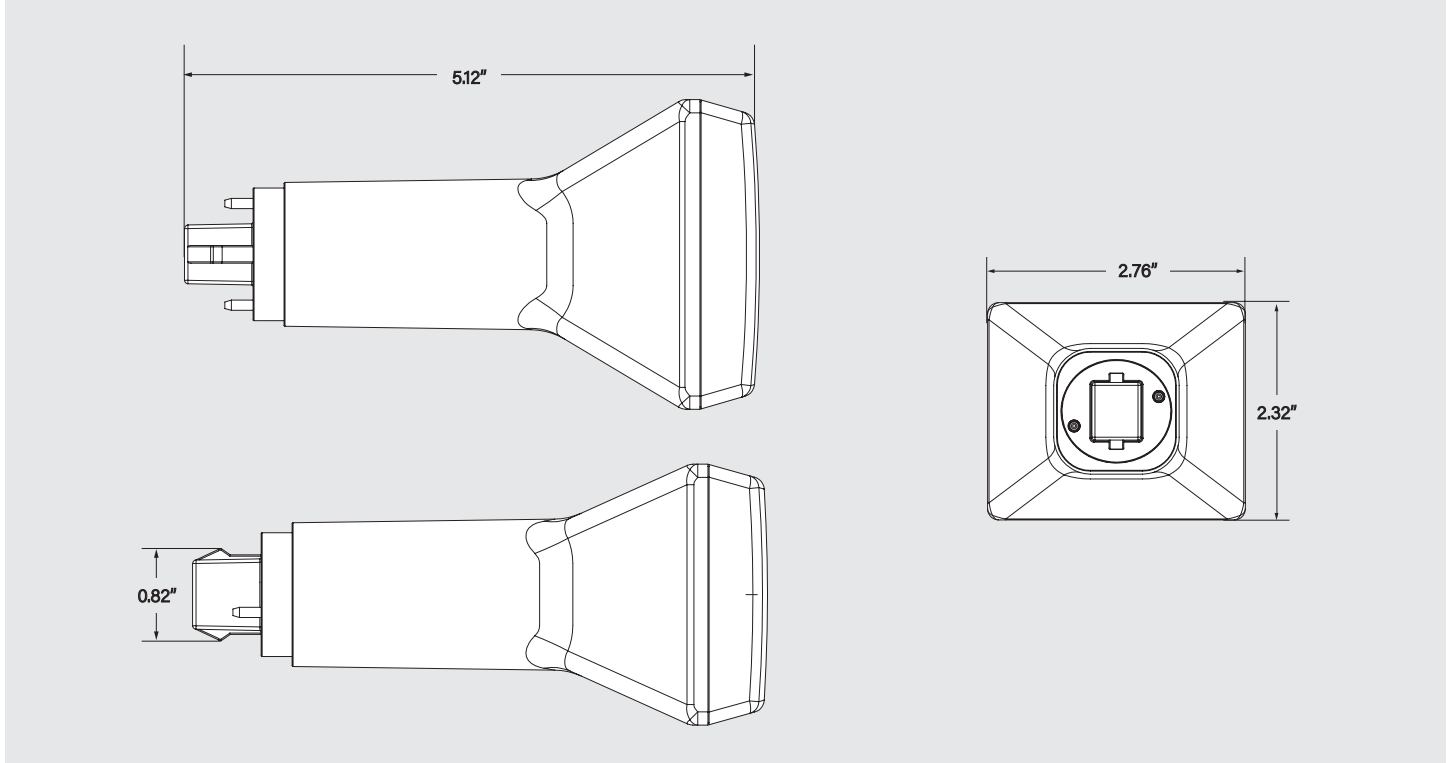

ORDERING INFORMATION

ORDER CODE	UPC	EASY CODE
KT-LED82P-V-835-D /G2	843654159126	AOZ-45
KT-LED82P-V-840-D /G2	843654159133	LMA-10
KT-LED82P-V-850-D /G2	843654159140	XMM-77

CATALOG NUMBER BREAKDOWN

KT-LED82P-V-8XX-D / G2

- 1
- 2
- 3
- 4
- 5
- 6
- 7
- 8
- 9

- 1** Keystone Technologies
- 2** LED Lamp
- 3** Wattage
- 4** Lamp Type
- 5** Vertical Orientation
- 6** 80 CRI
- 7** CCT
- 8** Direct Drive
- 9** Second Generation