



KTSL-FC4-12V-PKO

BLUETOOTH WIRELESS SMART PORT LUMINAIRE CONTROLLER

INSTALLATION AND OPERATING INSTRUCTIONS

Read and understand all warnings and notes stated below before proceeding with installation.

- Operating temperature: -25°C/-15°F to 60°C/140°F
- Do not use with enclosed metal luminaire.
- Use only one controller per luminaire.

Warning: Install/use in accordance with appropriate electrical codes and regulations.

Avertissement: Installer/utiliser conformément aux codes et réglementations électriques appropriés.

Warning: If you are not sure about any part of these instructions, consult a qualified electrician.

Avertissement: Si vous n'êtes pas sûr d'une partie de ces instructions, consultez un électricien qualifié.

Warning: Controlling a load in excess of the specified ratings will damage the unit and pose risk of fire, electric shock, personal injury, or death. Check your load ratings to determine the unit's suitability for your application.

Avertissement: Le contrôle d'une charge dépassant les valeurs nominales spécifiées endommagera l'unité et posera un risque d'incendie, de choc

électrique, de blessure corporelle ou de mort. Vérifiez vos capacités de charge pour déterminer l'adéquation de l'unité à votre application.

Warning: To avoid fire, shock, or death, turn off power at circuit breaker or fuse box and test to ensure that the power is off before wiring. Installation without cutting power may also cause device malfunction.

Avertissement: Pour éviter un incendie, une électrocution ou la mort, coupez l'alimentation au disjoncteur ou à la boîte à fusibles et testez pour vous assurer que l'alimentation est coupée avant de procéder au câblage. Une installation sans coupure de courant peut également entraîner un dysfonctionnement de l'appareil.

Cautions:

- Disconnect power when servicing luminaire or changing bulbs.
- Use this device with copper or copper-clad wire only. With aluminum wire, use devices marked CO/ALR or CU/AL only.
- Do not attempt to disassemble or repair.
- Clean outer surface with a damp cloth only.

Précautions:

- Débranchez l'alimentation lors de l'entretien du luminaire ou du changement d'ampoule.
- N'utilisez cet appareil qu'avec du fil de cuivre ou recouvert de cuivre.
- Avec du fil d'aluminium, utilisez uniquement des appareils marqués CO/ALR ou CU/AL.
- N'essayez pas de démonter ou de réparer. Nettoyez la surface extérieure avec un chiffon humide uniquement.



KTSL-FC4-12V-PKO

BLUETOOTH WIRELESS SMART PORT LUMINAIRE CONTROLLER

PHYSICAL SPECIFICATIONS

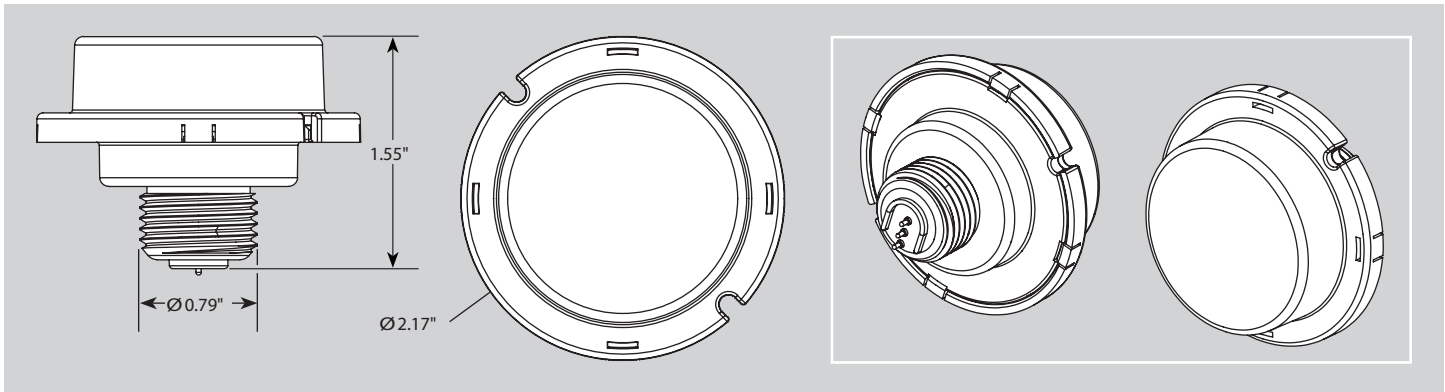

INSTALLING

1. Remove screw cover on Smart Port Gen 2 compatible Keystone product.
2. Screw-in sensor until snug.

SmartLoop Website



COMMISSIONING

1. Search for 'SmartLoop' on the app store for iPhone (iOS 8.0 or later, and Bluetooth 4.0 or later), or google play store for Android (Android 4.3 or later, and Bluetooth 4.0 or later).
2. With controllers installed and lights powered on, press + or Click to Add. The app will begin searching for available lights.
3. Check each light to be commissioned to the region.
4. Press Add to confirm selections. The selected lights will now appear on the Lights page.
5. For further system commissioning, see User Manual at www.keystonetech.com.

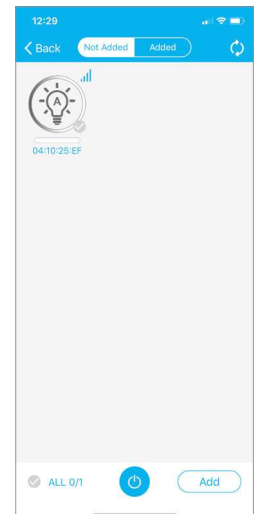



KTSL-FC4-12V-PKO

BLUETOOTH WIRELESS SMART PORT LUMINAIRE CONTROLLER

DECOMMISSIONING

Decommissioning can be done by deleting a controller from the region, a power reset sequence, or by using the reset button for certain models.

In the app:

The phone/tablet must be connected to the device through the mesh network in order for the controller to be factory reset. Otherwise, the light will simply be removed from the region in the app, and the controller will need to be factory reset using one of the other methods below.

1. Go to the Lights page.
2. Press Select and check the desired lights to decommission.
3. Press Delete and confirm.

Power cycle reset sequence:

If a controller is assigned to another region, it will not appear when searching for new fixtures. Perform the below power cycle sequence to factory reset the controller.

1. Power on for 1 second, then off for 10 seconds.
2. Power on for 1 second, then off for 10 seconds.
3. Power on for 1 second, then off for 10 seconds.
4. Power on for 10 seconds, then off for 10 seconds.
5. Power on for 10 seconds, then off for 10 seconds.
6. Turn the light back on. The device should now be decommissioned and ready to add to a region.

Reset button:

The reset button is accessed via a pinhole on the front face of the controller. While the device is powered, press and hold the button for 3 seconds to initiate a factory reset.

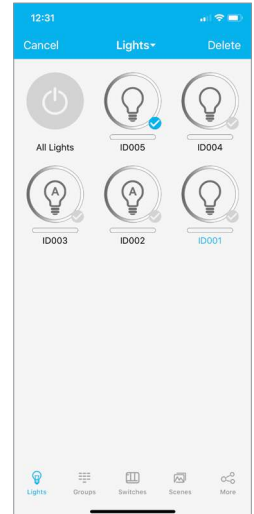

SAVE THESE INSTRUCTIONS