

INSTALLATION AND OPERATING INSTRUCTIONS

CAT. NO. KT-LED62P-HS-8XX-D

INSTALLATION

Product includes the following components:

PARTS	QUANTITY (Distributor Pack)
LED Lamp	1
Installation Instruction Sheet	1
Warning Label	1

WARNINGS

WARNING: Risk of fire or electric shock. This LED retrofit kit installation requires knowledge of luminaire electrical systems. If not qualified, do not attempt installation. Contact a qualified electrician.

AVERTISSEMENT: Risque d'incendie ou de choc électrique. Installation du kit de Retrofit LED exige une connaissance des systèmes électriques luminaire. Si vous n'êtes pas qualifié, ne tentez pas de l'installation. Contactez un électricien qualifié.

WARNING: Risk of fire or electric shock. Install this LED retrofit kit only in luminaires that have the construction features and dimensions shown in the photographs and/or drawings and where the input rating of the retrofit kit does not exceed the input rating of the luminaire.

AVERTISSEMENT: Risque d'incendie ou de choc électrique. Installez ce kit dans les luminaires qui ont les caractéristiques de construction et les dimensions indiquées dans les photographies et / ou dessins et où la cote d'entrée du kit de modification ne dépasse pas la capacité d'entrée du luminaire.

WARNING: To prevent wiring damage or abrasion, do not expose wiring to edges of sheet metal or other sharp objects.

AVERTISSEMENT: Pour éviter d'endommager le câblage ou à l'abrasion, ne pas exposer le câblage aux bords de tôle ou d'autres objets pointus.

IF LAMP DOES NOT LIGHT WHEN THE LUMINAIRE IS ENERGIZED, REMOVE LAMP FROM LUMINAIRE AND CONTACT LAMP MANUFACTURER OR QUALIFIED ELECTRICIAN.

SI LA LAMPE NE S'ALLUME PAS QUAND L'APPAREIL D'ÉCLAIRAGE ACTIVE, ENLEVEZ LA LAMPE DE L'APPAREIL D'ÉCLAIRAGE ET CONTACTEZ LE FABRICANT DE LAMPE OU UN ÉLECTRICIEN QUALIFIÉ.

CAUTION:

CAUTION: RISK OF FIRE - IF THE LAMP OR LUMINAIRE EXHIBITS UNDESIRABLE OPERATION (BUZZING, FLICKERING, ETC.), IMMEDIATELY TURN OFF POWER, REMOVE LAMP FROM LUMINAIRE AND CONTACT MANUFACTURER.

ATTENTION: RISQUE DE FEU - SI LA LAMPE OU LE LUMINAIRE MONTRE DES SIGNES D'OPERATION INDESIRABLE (BRUIT, VIBRATION, CLIGNOTEMENT, ETC.), ALORS COUPER IMMEDIATEMENT LE COURANT ET ENLEVER LA LAMPE DE L'APPAREIL D'ÉCLAIRAGE ENTRER EN CONTACT AVEC LE FABRICANT.

Do not make or alter any open holes in an enclosure of wiring or electrical components during kit installation.

DO NOT INSTALL THIS LAMP IN A PRE-HEAT LUMINAIRE.

Installers should not disconnect existing wires from lamp holder terminals to make new connections at lamp holder terminals. Instead, installers should cut existing lamp holder leads away from the lamp holder and make new electrical connections to lamp holder lead wires by employing applicable connectors.

THE RETROFIT KIT IS ACCEPTED AS A COMPONENT OF A LUMINAIRE WHERE THE SUITABILITY OF THE COMBINATION SHALL BE DETERMINED BY AUTHORITIES HAVING JURISDICTION. PRODUCT MUST BE INSTALLED BY A QUALIFIED ELECTRICIAN IN ACCORDANCE WITH THE APPLICABLE AND APPROPRIATE ELECTRICAL CODES. THE INSTALLATION GUIDE DOES NOT SUPERSEDE LOCAL OR NATIONAL REGULATIONS FOR ELECTRICAL INSTALLATIONS.

SAVE THESE INSTRUCTIONS

PRODUCT FEATURES

- UL Certified
- Two operation models
 - Direct replacement Mode
 - By Pass Mode

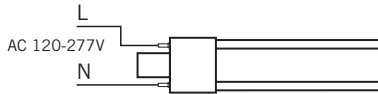

PRODUCT APPLICATIONS

Widely used in residential buildings, offices, shopping malls, supermarkets, hospitals, assembly lines, warehouses, etc. for energy saving illumination.

INSTALLATION INSTRUCTIONS

Please completely comply with these instructions and notes, to ensure that the product is operated in a safe condition.

SAFETY INFORMATION

1. Check the lamp before installation, if there is any damage caused during transportation, do not install.
2. Maintenance should be carried out by technical personnel only.
3. Do not stare at the light source with bare eyes for a long time, or beam to others' eyes.
4. Do not place any objects on the lamp.
5. Keep the lamp away from flame or high temperature objects.
6. Only replace with same type of LED lamp. Risk of electric shock.
7. If the lamp is broken, the lamp must be disposed of immediately.

MAINTENANCE NOTES

1. Disconnect lamp from power supply before any maintenance.
2. Clean luminaire with dry cloth.
3. Do not clean the lamp with corrosive chemicals.

SAFETY PRECAUTIONS

For your and others' safety, please read the precaution carefully before installation.

1. WARNING: Risk of shock. Disconnect power before installation.
2. WARNING: Risk of fire, use only in place of fluorescent lamps specified on label. Risk of electric shock. Suitable for damp locations.
3. Product should be installed by qualified electrician.
4. Not for emergency lighting.
5. The devices are intended to retrofit surface mount Type IC or non-IC recessed mount Listed fluorescent luminaires that use maximum two lamps with or without a diffused the minimum dimension of luminaires are tabulated below:

KEYSTONE CATALOG NUMBER	MAX NO. OF LAMP	MINIMUM LAMP COMPARTMENT DIMENSIONS	LAMP-TO-LAMP SPACING
KT-LED62P-HS-8XX-D	2	22 cm (L) x 14.5 cm (W) x 11 cm (H)	1 cm

WIRING

BYPASS BALLAST WITH 1 LAMP (Gx23 SOCKET)

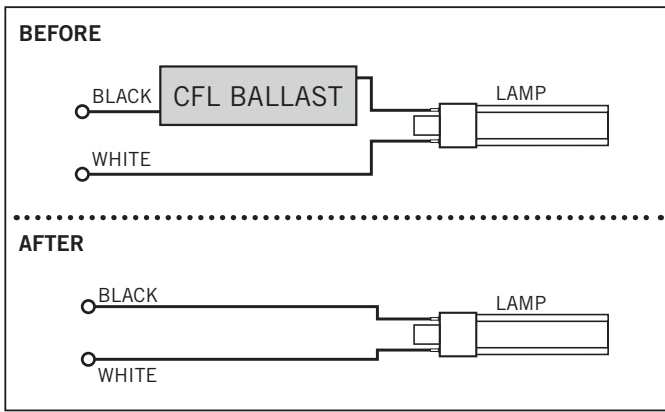

BYPASS BALLAST WITH 2 LAMPS (Gx23 SOCKET)

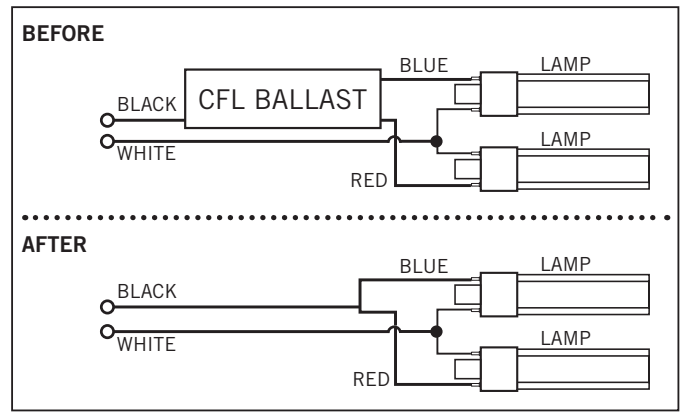

INSTALLATION.

Removing existing fluorescent system:

1. Disconnect power from the Lamp.
2. Remove lens or diffuser if applicable.
3. Remove existing fluorescent lamps from the luminaire.
4. Bring LED lamp to luminaire and insert lamp pins into luminaire lamp holders.
5. Place lens or diffuser back in place (if applicable)
6. Power ON

