



REVERSIBLE GLARE SHIELD KITS

DESCRIPTION

Reversible (house side/street side) glare shield kits | For use on Area Lights with OpticSwap | Bronze, white, black, and silver options available



COLOR OPTIONS

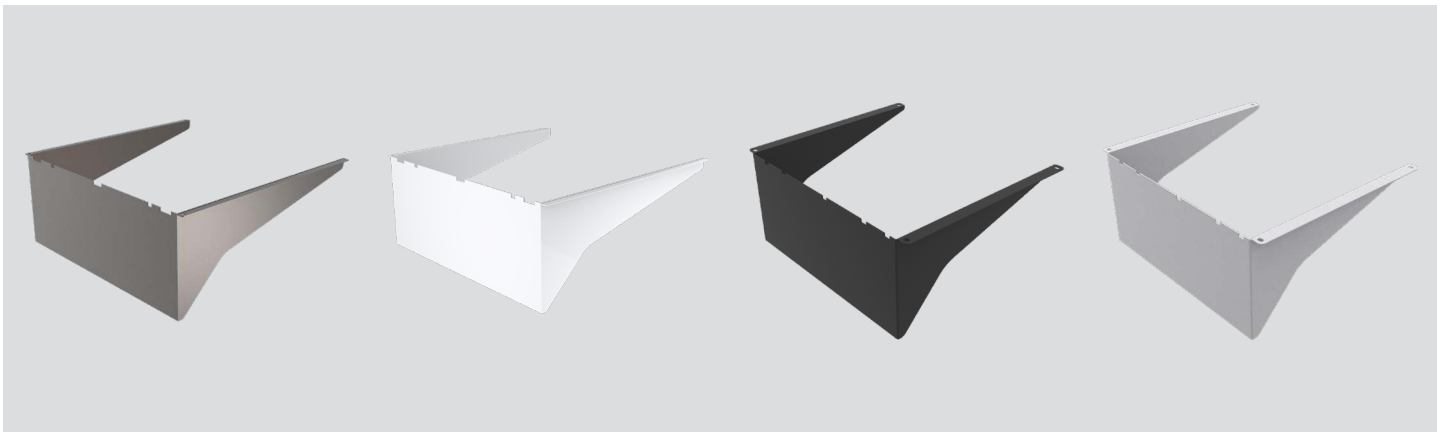

PRODUCT SPECIFICATIONS

SMALL

Catalog Number	Description	Finish Color
KT-ALED-GS-S2-KIT	Reversible Glare Shield for Small Size Housing; Area Lights with OpticSwap	Bronze

MEDIUM

Catalog Number	Description	Finish Color
KT-ALED-GS-M2-KIT	Reversible Glare Shield for Medium Size Housing; Area Lights with OpticSwap	Bronze
KT-ALED-GS-M2-KIT-W	Reversible Glare Shield for Medium Size Housing; Area Lights with OpticSwap	White
KT-ALED-GS-M2-KIT-B	Reversible Glare Shield for Medium Size Housing; Area Lights with OpticSwap	Black
KT-ALED-GS-M2-KIT-S	Reversible Glare Shield for Medium Size Housing; Area Lights with OpticSwap	Silver

LARGE

Catalog Number	Description	Finish Color
KT-ALED-GS-L2-KIT	Reversible Glare Shield for Large Size Housing; Area Lights with OpticSwap	Bronze
KT-ALED-GS-L2-KIT-W	Reversible Glare Shield for Large Size Housing; Area Lights with OpticSwap	White
KT-ALED-GS-L2-KIT-B	Reversible Glare Shield for Large Size Housing; Area Lights with OpticSwap	Black
KT-ALED-GS-L2-KIT-S	Reversible Glare Shield for Large Size Housing; Area Lights with OpticSwap	Silver



REVERSIBLE GLARE SHIELD KITS

PHYSICAL SPECIFICATIONS

Size	A	B	C	D
Small	8.10"	9.69"	4.17"	4.17"
Medium	9.53"	11.35"	4.76"	4.76"
Large	12.47"	14.07"	5.49"	5.49"

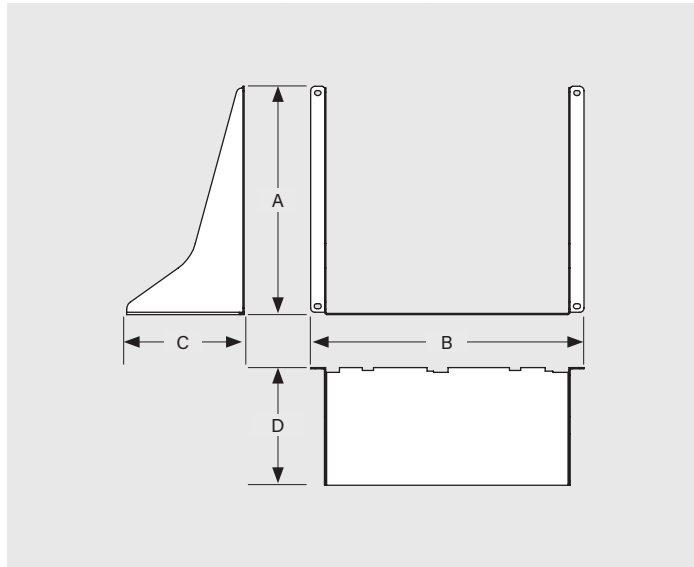

ORDERING INFORMATION

SMALL

ORDER CODE	UPC	EASY CODE
KT-ALED-GS-S2-KIT	843654153780	PME-57

MEDIUM

ORDER CODE	UPC	EASY CODE
KT-ALED-GS-M2-KIT	843654153797	HEM-55
KT-ALED-GS-M2-KIT-W	843654153803	GMR-48
KT-ALED-GS-M2-KIT-B	843654164410	WBV-17
KT-ALED-GS-M2-KIT-S	843654164427	QMH-33

LARGE

ORDER CODE	UPC	EASY CODE
KT-ALED-GS-L2-KIT	843654153810	RDW-18
KT-ALED-GS-L2-KIT-W	843654153827	DQV-16
KT-ALED-GS-L2-KIT-B	843654164434	ODJ-17
KT-ALED-GS-L2-KIT-S	843654164441	PEN-02

CATALOG NUMBER BREAKDOWN

KT-ALED-GS-X2-KIT-X

1 2 3 4 5 6 7 8

1 Keystone Technologies

2 Fixture Type

3 LED Technology

4 Glare Shield

5 Size/Shape

6 Style/Design Designation

7 Kit

8 Finish Color

2 Fixture Type

A	Area Light
---	------------

5 Size / Shape

S	Small
M	Medium
L	Large

6 Style/Design Designation

2	Area Lights with OpticSwap
---	----------------------------

8 Finish Color

	Bronze
W	White
B	Black
S	Silver