

KT-RKIT32PS-4S-8CSA-VDIM / KT-RKIT55PS-8S-8CSA-VDIM

LED RETROFIT STRIP FIXTURE KIT

INSTALLATION INSTRUCTIONS

PLEASE FIND A QUALIFIED ELECTRICIAN FOR INSTALLATION. Please read the instructions before installation and use.

WARNING

- To reduce the risk of death, personal injury or property damage from fire, electric shock, failing parts, cuts/abrasions, and other hazards. Read all warnings and instructions with and on the fixture box and all fixture labels.
- Before installing, servicing, or performing routine maintenance upon this equipment, follow these general precautions.
- Commercial installation, service, and maintenance of luminaires should be performed by a qualified, licensed electrician.
- For the installation: If you are unsure about the installation or maintenance of the luminaires, consult a qualified, licensed electrician and check your local electrical code.
- To prevent wiring damage or abrasion, do not expose wiring to edges of sheet metal or other sharp objects.
- Do not make or alter any open holes in an enclosure of wiring or electrical components during kit installation.

WARNING

- Turn off electrical power at fuse or circuit breaker box before wiring fixture to the power supply.
- Turn off the power when you perform any maintenance.
- Verify that supply voltage is correct by comparing it with the luminaire label information.
- All wiring connections should be capped with UL approved wire connectors.

CAUTION

- Avoid direct eye exposure to the light source while it is on.
- Account for small parts and destroy packing material, as these may be hazardous to children.
- Risk of burn. Disconnect power and allow fixture to cool before changing bulb or handling fixture.

NOTES

- Green ground screw provided in proper location. Do not relocate.
- Minimum 90° supply conductors.
- Specifications and dimensions subject to change without notice.
- Suitable for dry or damp locations.

COMPONENTS INCLUDED IN KIT

KT-RKIT32PS-4S-8CSA-VDIM

Part	Quantity
Retrofit Housing	1
Installation Bracket	2
Lens	1
Retrofit Label	1
Instruction Sheet	1

KT-RKIT55PS-8S-8CSA-VDIM

Part	Quantity
Retrofit Housing	1
Installation Bracket	4
Lens	2
Retrofit Label	1
Instruction Sheet	1

Caution: Before installing, make certain that AC power to the fixture is off.

GENERAL SETUP INSTRUCTIONS

WIRING DIAGRAM

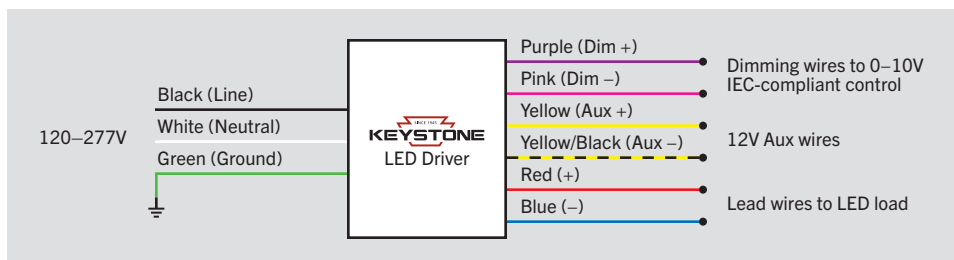

**In accordance with NEC-20 410.69 2022, all 0-10V negative wires have been updated from gray to pink. Please contact Keystone for details.*

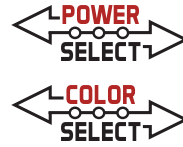

XFIT

KT-RKIT32PS-4S-8CSA-VDIM / KT-RKIT55PS-8S-8CSA-VDIM LED RETROFIT STRIP FIXTURE KIT

GENERAL SETUP INSTRUCTIONS (continued)

POWER SELECT (WATTAGE) AND COLOR SELECT (CCT) ADJUSTMENT

This fixture is equipped with field-adjustable Power Select and Color Select technology.

1. Ensure power is off to the fixture.
2. Adjust dip switches to desired settings.

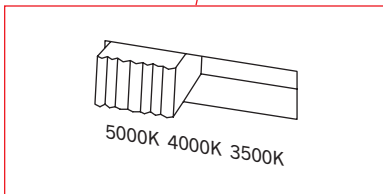
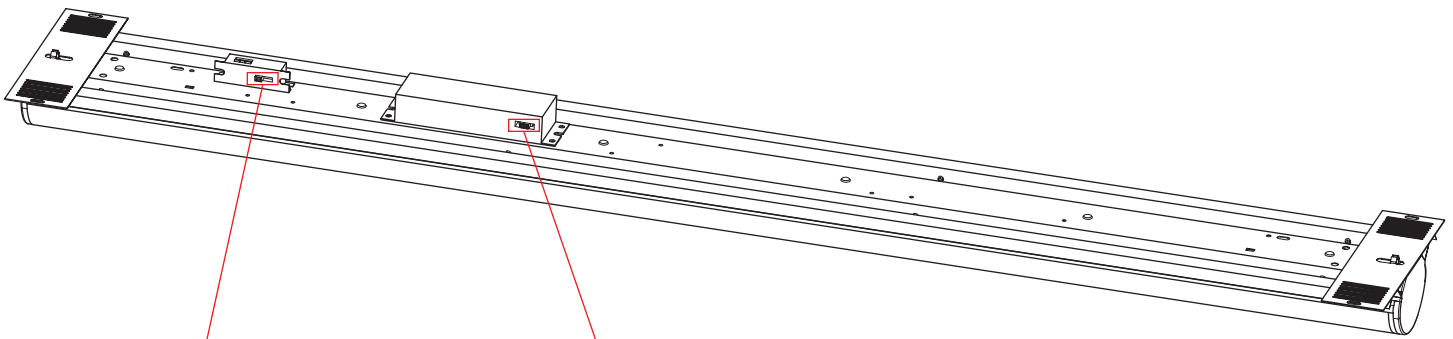

COLOR SELECT ADJUSTMENT SWITCH

Set dip switch to adjust CCT between 5000K, 4000K, and 3500K. Fixture comes preset at 5000K.

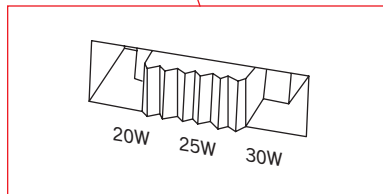

POWER SELECT ADJUSTMENT SWITCH

Set dip switch to adjust wattage.

KT-RKIT32PS-4S-8CSA-VDIM / KT-RKIT55PS-8S-8CSA-VDIM LED RETROFIT STRIP FIXTURE KIT

INSTALLATION

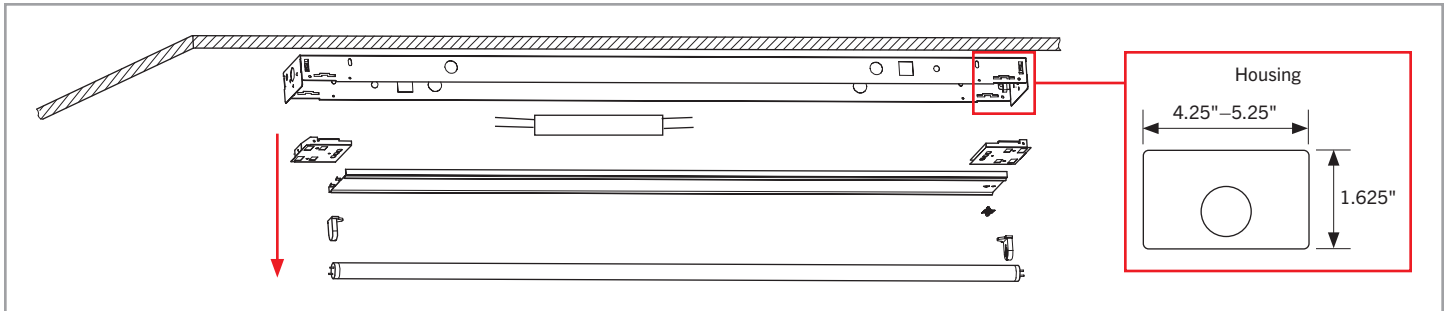

1. Shut off power to existing fixture.
2. Disconnect the black and the white power supply wire to existing ballast.
3. Remove and discard the host fixture lamp(s).
4. Remove ballast cover, ballast, socket-bars, and wiring.

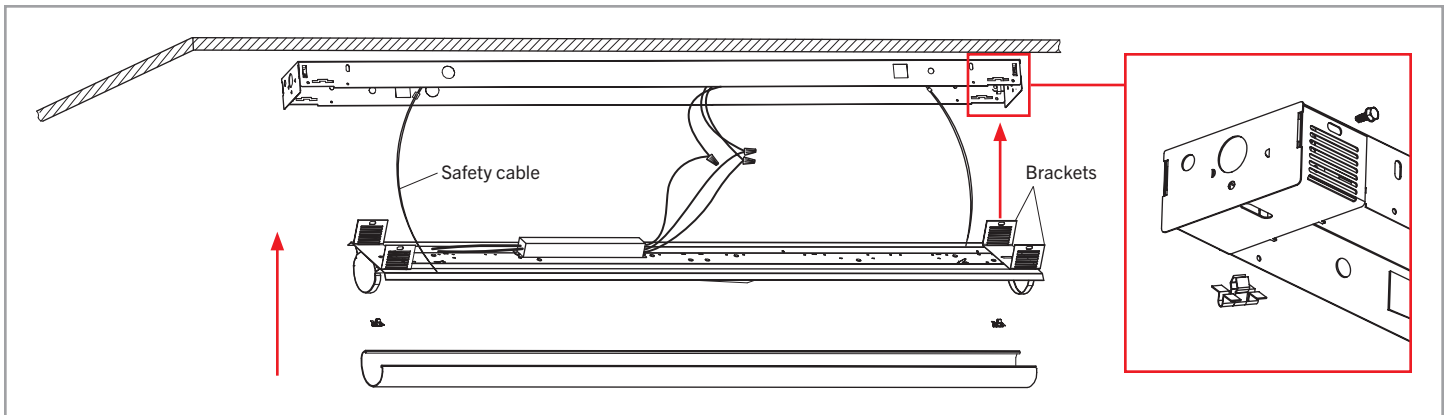

5. Install brackets.
6. Make all electrical connections to the fixture.
7. Install LED retrofit assembly.
8. Install optional lens.
9. Attach pre-installed safety cable to secure fixture in accordance with local building codes.

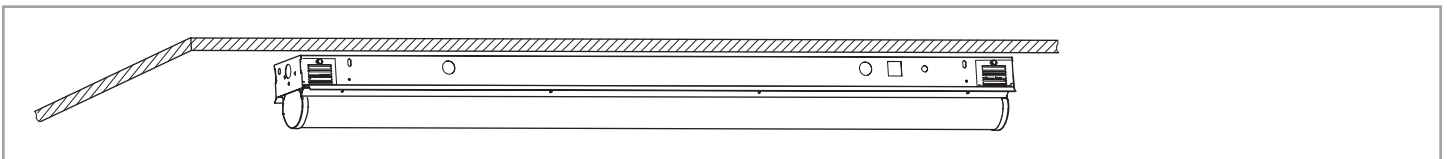

10. Affix retrofit label to housing.
11. Turn on power to the fixture.

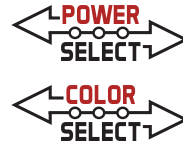

XFIT

KT-RKIT32PS-4S-8CSA-VDIM / KT-RKIT55PS-8S-8CSA-VDIM LED RETROFIT STRIP FIXTURE KIT

ORDERING INFORMATION

Catalog Number	PACK QTY.	UPC	Easy Code
KT-RKIT32PS-4S-8CSA-VDIM	1	843654134864	JQM-63
KT-RKIT55PS-8S-8CSA-VDIM	1	843654134871	IAY-20