



HPS-100X-Q-KIT

100W HIGH PRESSURE SODIUM BALLAST KIT



DESCRIPTION

100W High Pressure Sodium HID Replacement Kit | Quad Tap 120/208/240/277

LAMP TYPE: 100W High Pressure Sodium (S54)
INPUT VOLTAGE: Quad Tap (120/208/240/277V)
CIRCUIT TYPE: HX-HPF
WARRANTY: 2 Years

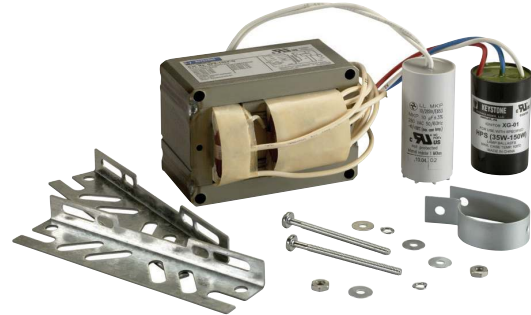

PRODUCT FEATURES

- ANSI Designation: S54
- Line Voltage: 120/208/240/277
- Regulation: 5%
- Frequency: 60 Hz
- Recommended Fuse (A): 8/5/5/3
- Circuit Type: HX-HPF
- Insulation Class: 180°C
- Capacitor: 10 μ F
- Capacitor Voltage Rating: 280 V
- Capacitor Temperature Rating: 90°C
- Winding Materials: Copper
- Lamp Starter: XG-01
- Agency Certification: RU, cRU
- Maximum Distance to Lamp: 10 ft.

ELECTRICAL SPECIFICATIONS

LINE VOLTAGE	POWER FACTOR	LINE CURRENT			INPUT POWER	OPEN CIRCUIT VOLTAGE	MINIMUM START TEMP	CLASS N 200°C UL TEMP CODE
		OPERATING	OPEN CIRCUIT	STARTING				
120V	High	1.16A	2.20A	1.00A	122W	120V	-40°F/-40°C	A
208V	High	0.68A	1.35A	0.66A	122W	120V	-40°F/-40°C	A
240V	High	0.58A	1.10A	0.50A	122W	120V	-40°F/-40°C	A
277V	High	0.50A	0.95A	0.42A	122W	120V	-40°F/-40°C	A

WIRING DIAGRAM

DIAGRAM H5

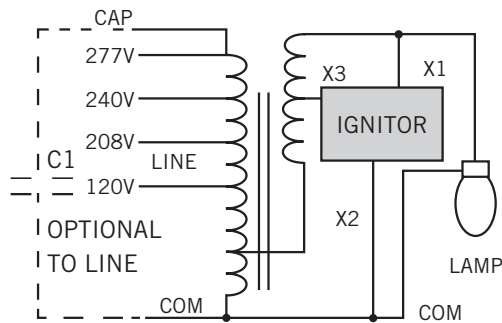

H5

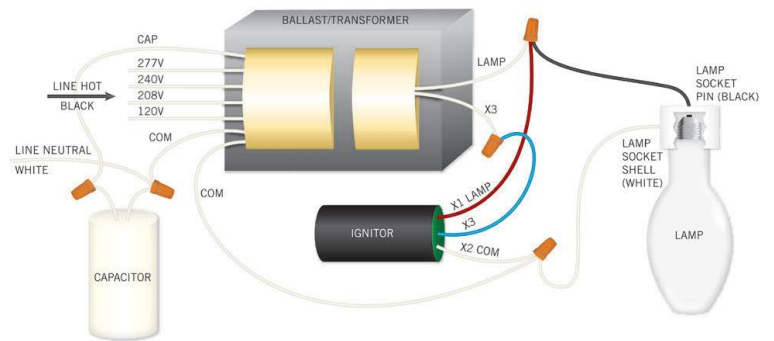

(Capacitor is optional on HX models)

Colors shown represent the most common configuration. However, depending on the application and local code, slight differences may exist.



HPS-100X-Q-KIT

100W HIGH PRESSURE SODIUM BALLAST KIT

PHYSICAL SPECIFICATIONS

CASE STYLE

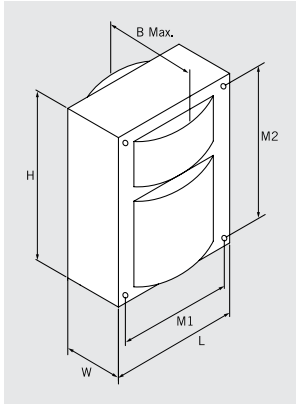

OVERALL DIMENSIONS

Length	Width	Height	B Max.
2.80"	1.99"	3.94"	3.35"

MOUNTING HOLES

Diameter	M1	M2
0.25"	2.44"	3.50"

BRACKET DIMENSIONS		Ballast Net Weight	Lead Length
Length	Width	6.17 lbs	12-14"
5.50"	1.25"		

CAPACITOR SPECIFICATIONS

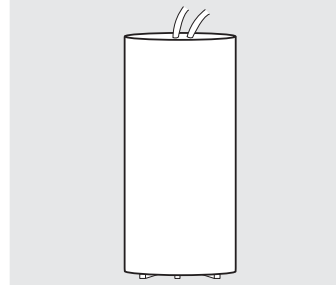

Wattage	100
Microfarad	10
Voltage	280
Type	Dry Film

IGNITOR SPECIFICATIONS

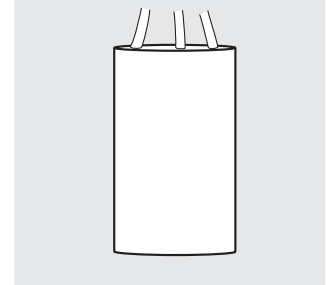

Lamp Type	HPS
Wattage	100
Type	HX-HPF

ORDERING INFORMATION

ORDER CODE	PACK QTY.	ITEM STATUS
HPS-100X-Q-KIT	1	Quick Ship

Each kit includes the ballast pre-wired to a properly rated capacitor and ignitor (if required), mounting hardware, and pictorial installation guide.

CATALOG NUMBER BREAKDOWN

HPS-100X-Q-KIT

1

2

3

4

5

- 1 High Pressure Sodium
- 2 Input Power
- 3 Circuit Reactor
- 4 120/208/240/277V, Quad Tap
- 5 HID Replacement Kit