



HPS-150R-1-KIT

150W HIGH PRESSURE SODIUM BALLAST KIT



DESCRIPTION

150W High Pressure Sodium Ballast Kit | 120V

LAMP TYPE: 150W High Pressure Sodium (S55)
INPUT VOLTAGE: Single (120V)
CIRCUIT TYPE: R-NPF/R-HPF
WARRANTY: 2 Years



PRODUCT FEATURES

- ANSI Designation: S55
- Line Voltage: 120V
- Regulation: 5%
- Frequency: 60 Hz
- Recommended Fuse (A): 15
- Circuit Type: R-NPF/R-HPF
- Insulation Class: 180°C
- Capacitor: 55 μ F
- Capacitor Voltage Rating: 120V Min.
- Capacitor Temperature Rating: 90°C
- Winding Materials: Copper/Copper
- Lamp Starter: XG-01
- Agency Certification: RU, cRU
- Maximum Distance to Lamp: 3 ft.

ELECTRICAL SPECIFICATIONS

LINE VOLTAGE	POWER FACTOR	LINE CURRENT			INPUT POWER	OPEN CIRCUIT VOLTAGE	MINIMUM START TEMP	CLASS N 200°C UL TEMP CODE
		OPERATING	OPEN CIRCUIT	STARTING				
120V	NPF	3.50A	N/A	4.50A	163W	120V	-40°F/-40°C	A

WIRING DIAGRAM

DIAGRAM H1

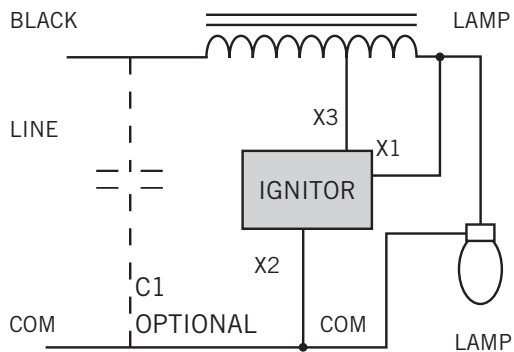

H1

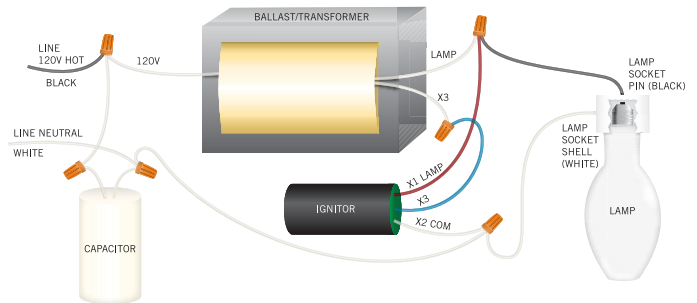

(Capacitor is optional on HX models)

Colors shown represent the most common configuration. However, depending on the application and local code, slight differences may exist.



HPS-150R-1-KIT

150W HIGH PRESSURE SODIUM BALLAST KIT

PHYSICAL SPECIFICATIONS

CASE STYLE

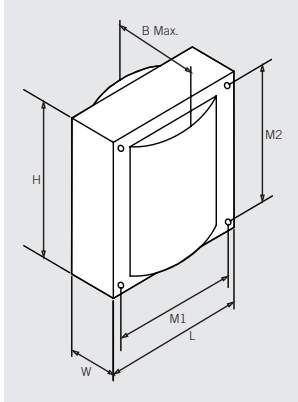

OVERALL DIMENSIONS

Length	Width	Height	B Max.
2.64"	2.25"	2.09"	3.35"

MOUNTING HOLES

Diameter	M1	M2
1.33"	2.19"	1.79"

BRACKET DIMENSIONS		Ballast Net Weight	Lead Length
Length	Width		
N/A	N/A	3.27 lbs	12-14"

IGNITOR SPECIFICATIONS

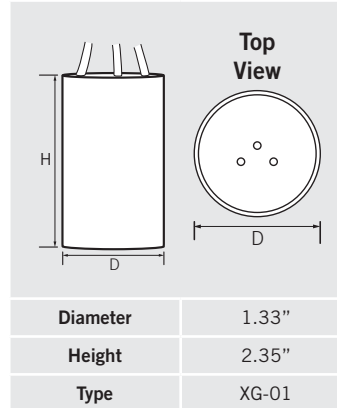

Diameter	1.33"
Height	2.35"
Type	XG-01

ORDERING INFORMATION

CATALOG NUMBER	PACK QTY.	EASY CODE	UPC
HPS-150R-1-KIT	1	ZPW-18	89094900730

Each kit includes the ballast pre-wired to a properly rated capacitor and ignitor (if required), mounting hardware, and pictorial installation guide.

CATALOG NUMBER BREAKDOWN

HPS-150R-1-KIT

1 **2** **3** **4** **5**

- 1 High Pressure Sodium
- 2 Input Power
- 3 Circuit Reactor
- 4 120 V Single Tap
- 5 HID Replacement Kit