



# ESSENTIAL SERIES

GENERAL PURPOSE LED BULBS

## KT-LED6.5MR16-S-8XX-GU10 /G2 REPLACEMENT LAMP

### DESCRIPTION

6.5W MR16 Lamp | 2700–5000K | ≥80 CRI | Spot Light



<b>LAMP TYPE:</b> MR16
<b>BASE TYPE:</b> GU10
<b>WATTAGE:</b> 6.5W
<b>COLOR TEMPERATURE:</b> 2700–5000K
<b>COLOR RENDERING INDEX (CRI):</b> ≥ 80
<b>WARRANTY:</b> 3 Years
<b>RATED LIFE:</b> L70 (25,000 Hours)



### TYPICAL APPLICATIONS

- Track-lighting
- Display
- Under-cabinet
- Outdoor landscaping (with suitable protection from the elements)

### PRODUCT FEATURES

- Energy efficient, 80%+ energy savings over legacy equivalents
- Lower heat generation than legacy equivalents
- Smooth, uniform dimming
- Precision-crafted, full-face optics for precise beam angle control
- Durable plastic housing lowers the risk of breakage
- Long life minimizes replacement and maintenance costs
- Compatible with Keystone low voltage transformers
- Suitable for damp locations
- Operating temperature range –4°F/–20°C to 95°F/35°C
- PF > 0.70
- Rated for open, recessed, and enclosed fixtures
- ANSI compliant construction ensures fitment for intended applications
- UL Listed
- Meets Energy Star requirements
- Complies with Part 15 of FCC

### ELECTRICAL AND PERFORMANCE SPECIFICATIONS

Keystone Catalog Number	Description	Color Temp	Input Voltage	Rated Lamp Wattage	Legacy Equivalent Wattage	Lumens	Efficacy	CRI	Base Type	Beam Angle	Dimmable
KT-LED6.5MR16-S-827-GU10 /G2	MR16 bulb; Spot light; Dimmable	2700K	120V	6.5W	50W halogen	500 lm	77 lm/W	≥80	GU10	40°	Yes
KT-LED6.5MR16-S-830-GU10 /G2	MR16 bulb; Spot light; Dimmable	3000K	120V	6.5W	50W halogen	500 lm	77 lm/W	≥80	GU10	40°	Yes
KT-LED6.5MR16-S-840-GU10 /G2	MR16 bulb; Spot light; Dimmable	4000K	120V	6.5W	50W halogen	500 lm	77 lm/W	≥80	GU10	40°	Yes
KT-LED6.5MR16-S-850-GU10 /G2	MR16 bulb; Spot light; Dimmable	5000K	120V	6.5W	50W halogen	500 lm	77 lm/W	≥80	GU10	40°	Yes

## KT-LED6.5MR16-S-8XX-GU10 /G2 REPLACEMENT LAMP

### PHYSICAL CHARACTERISTICS

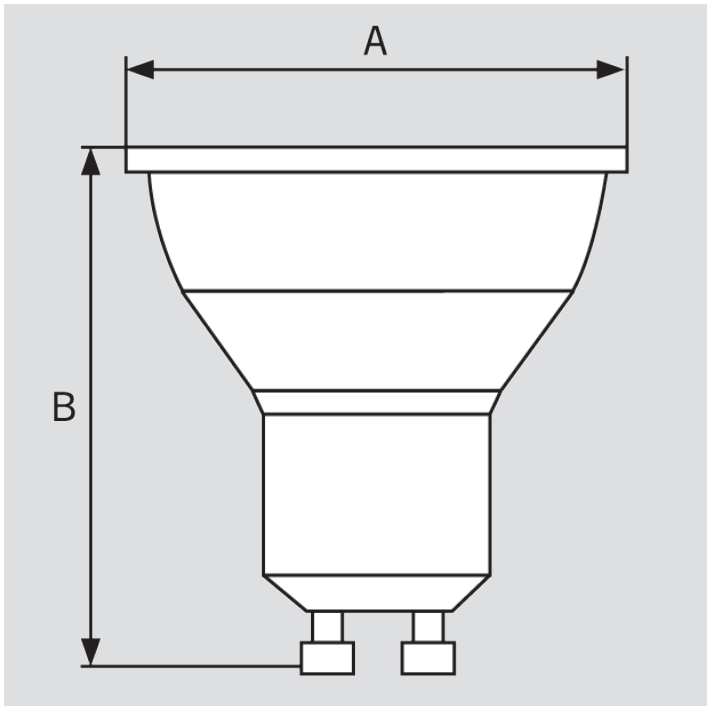

#### LAMP DIMENSIONS

A (Diameter)	1.97"
B (Length)	2.19"

BASE TYPE: GU10

#### RATED LIFE

L70 (Hours)	25,000
-------------	--------

#### PACKAGING

Carton Quantity	60 pcs
Carton Dimensions	12.95" × 10.91" × 6.54"
Carton Weight	9.5 lbs

### ORDERING INFORMATION

ORDER CODE	CARTON QUANTITY	ITEM STATUS	EASY CODE	UPC
KT-LED6.5MR16-S-827-GU10 /G2	60 pcs	Active	YGE-97	843654138565
KT-LED6.5MR16-S-830-GU10 /G2	60 pcs	Active	SWO-33	843654138572
KT-LED6.5MR16-S-840-GU10 /G2	60 pcs	Active	ZXH-76	843654138589
KT-LED6.5MR16-S-850-GU10 /G2	60 pcs	Active	DGK-79	843654138596

### CATALOG NUMBER BREAKDOWN

## KT-LED6.5MR16-S-8XX-GU10 /G2

1 2 3 4 5 6 7 8 9

- 1 Keystone Technologies
- 2 LED Lamp
- 3 Wattage
- 4 Multi-Faceted Reflector
- 5 Spot Light
- 6 80 CRI
- 7 Color Temperature
- 8 Base Type
- 9 Generation 2